

SYBASE®

Administration Guide

Mirror Activator™

15.0

[Linux, Microsoft Windows, and UNIX]

DOCUMENT ID: DC00710-01-1500-01

LAST REVISED: March 2007

Copyright © 2004-2007 by Sybase, Inc. All rights reserved.

This publication pertains to Sybase software and to any subsequent release until otherwise indicated in new editions or technical notes. Information in this document is subject to change without notice. The software described herein is furnished under a license agreement, and it may be used or copied only in accordance with the terms of that agreement.

To order additional documents, U.S. and Canadian customers should call Customer Fulfillment at (800) 685-8225, fax (617) 229-9845.

Customers in other countries with a U.S. license agreement may contact Customer Fulfillment via the above fax number. All other international customers should contact their Sybase subsidiary or local distributor. Upgrades are provided only at regularly scheduled software release dates. No part of this publication may be reproduced, transmitted, or translated in any form or by any means, electronic, mechanical, manual, optical, or otherwise, without the prior written permission of Sybase, Inc.

Sybase trademarks can be viewed at the [Sybase trademarks page at http://www.sybase.com/detail?id=1011207](http://www.sybase.com/detail?id=1011207). Sybase and the marks listed are trademarks of Sybase, Inc. ® indicates registration in the United States of America.

Java and all Java-based marks are trademarks or registered trademarks of Sun Microsystems, Inc. in the U.S. and other countries.

Unicode and the Unicode Logo are registered trademarks of Unicode, Inc.

All other company and product names used herein may be trademarks or registered trademarks of their respective companies.

Use, duplication, or disclosure by the government is subject to the restrictions set forth in subparagraph (c)(1)(ii) of DFARS 52.227-7013 for the DOD and as set forth in FAR 52.227-19(a)-(d) for civilian agencies.

Sybase, Inc., One Sybase Drive, Dublin, CA 94568.

Contents

About This Book	v	
CHAPTER 1	Introduction to Mirror Activator	1
	Disaster recovery options.....	1
	Disk replication	1
	Transaction replication	2
	The Mirror Activator solution	4
	Mirror Activator advantages	4
	How Mirror Activator works	5
	ASE	5
	Oracle.....	6
	Mirror Activator system components	7
	Materializing the standby database.....	9
	Fault tolerance and automatic recovery	10
	Introduction to Mirror Replication Agent.....	11
CHAPTER 2	Setting Up and Configuring Mirror Replication Agent	17
	Setting up the Mirror Activator system	17
	Installation and basic configuration	18
	Setting up a new Mirror Activator system.....	19
	Mirror Activator configuration requirements	38
	Using Mirror Replication Agent utilities.....	40
	Preparing to use the utilities	40
	Using the command line interface	42
	Starting the Mirror Replication Agent	61
	Start-up requirements.....	62
	Setting character sets.....	62
	Starting an instance with the ma utility	65
	Starting an instance with the RUN script.....	66
	Using the Mirror Replication Agent administration port.....	68
	Creating an entry in the interfaces file	68
	Logging in to the Mirror Replication Agent using isql	69
	Creating the Mirror Replication Agent administrator login	70

Setting up Mirror Replication Agent connectivity.....	71
Creating the primary database user login name	72
Creating the Replication Server user login name.....	72
Creating the RSSD user login name	73
Setting up the connection configuration parameters	76
Testing network connectivity	80
Marking objects in the primary database	82
Marking tables in the primary database	83
Marking stored procedures in the primary database	85
Enabling replication for LOB columns	86
Enabling replication for DDL.....	88

CHAPTER 3

Administering Mirror Replication Agent.....	89
Determining current Mirror Replication Agent status	89
Understanding Mirror Replication Agent states.....	90
Changing the Mirror Replication Agent state.....	92
Getting Mirror Replication Agent statistics	93
Shutting down the Mirror Replication Agent instance	93
Starting replication in the Mirror Replication Agent	95
Stopping replication in the Mirror Replication Agent	96
Quiescing the Mirror Replication Agent.....	97
Suspending the Mirror Replication Agent instance	98
Managing the Mirror Replication Agent transaction log	99
Initializing the Mirror Replication Agent transaction log.....	100
Removing the Mirror Replication Agent transaction log	102
Forcing transaction log removal	104
Truncating the Mirror Replication Agent transaction log	105
Backing up Mirror Replication Agent objects in the primary database.....	107
Managing the Replication Agent System Database	107
RASD overview	107
Updating the RASD	109
Updating the log device repository	112
Backing up the RASD.....	114
Restoring the RASD	115
Truncating the RASD	116
Identifying replicated transactions and procedures.....	117
Preparing to mark tables or stored procedures	119
Marking and unmarking tables	119
Enabling and disabling replication for DDL	124
Enabling and disabling replication for marked tables	126
Enabling and disabling replication for LOB columns	128
Marking and unmarking stored procedures.....	131
Enabling and disabling replication for stored procedures.....	136

	Marking and unmarking sequences (for Oracle only).....	138
	Enabling and disabling replication for sequences (for Oracle only)	
	142	
	Configuring and tuning the Mirror Replication Agent	144
	Configuring Mirror Replication Agent	151
	Customizing tuning	151
CHAPTER 4	Troubleshooting Mirror Replication Agent.....	155
	Diagnosing command errors and replication errors	155
	Troubleshooting specific command errors	156
	Connection refused	156
	Examining the Mirror Replication Agent if a failure occurs.....	156
	Verify primary database objects marked for replication	157
	Check the Mirror Replication Agent status	158
	Examine the Mirror Replication Agent logs	160
	Use the ra_statistics command to troubleshoot	161
	Check available memory	162
	Checking the Replication Server	164
	Check status and operation.....	165
	Mirror Replication Agent login in Replication Server	165
	Verify stable queues	167
APPENDIX A	Materializing Databases in a Mirror Activator system.....	169
	Selecting a materialization option	169
APPENDIX B	Failover and Failback with Mirror Activator	173
	Limitations and assumptions.....	173
	Failover procedure	174
	Failback procedure.....	177
Glossary		181
Index		191

About This Book

This book describes the Sybase[®] Mirror Activator[™] software solution that allows you to combine the benefits of transaction replication and disk replication, thereby eliminating the disadvantages of using either system alone in a disaster recovery solution.

The Mirror Activator solution includes the following Sybase software products:

- Mirror Replication Agent[™]
- Replication Server[®]
- Enterprise Connect[™] Data Access Option for Oracle (DirectConnect[™] for Oracle only)

Audience

This book is for anyone who needs to manage or administer a Mirror Activator system. This may include:

- System Administrators
- Database Administrators
- Network Administrators

How to use this book

This book is organized as follows:

Chapter 1, “Introduction to Mirror Activator,” provides an overview of replication solutions for disaster recovery, and introduces the Mirror Activator solution and the Mirror Replication Agent component.

Chapter 2, “Setting Up and Configuring Mirror Replication Agent,” describes how to set up and configure the Mirror Replication Agent, and other software components of the Mirror Activator system.

Chapter 3, “Administering Mirror Replication Agent,” describes administrative tasks and procedures for the Mirror Replication Agent.

Chapter 4, “Troubleshooting Mirror Replication Agent,” describes basic troubleshooting and system recovery procedures.

Appendix A, “Materializing Databases in a Mirror Activator system,” describes how to materialize the databases in a Mirror Activator system.

Appendix B, “Failover and Failback with Mirror Activator,” describes procedures for failover and failback in a Mirror Activator system.

Related documents

If you are not familiar with Sybase transaction replication technology, refer to the following documents for more information:

- Replication Server *Design Guide* for an introduction to basic transaction replication concepts and Sybase transaction replication systems
- Replication Server *Administration Guide* for an introduction to Replication Server support for warm standby applications
- Replication Server *Heterogeneous Replication Guide* for detailed information about configuring Replication Server and implementing a Sybase replication system with non-Sybase databases

To learn more about the Mirror Activator solution and the Mirror Replication Agent component, refer to the following documents:

- Mirror Replication Agent *Reference Manual* for information about all Mirror Replication Agent commands and configuration properties, including syntax, examples, and detailed command usage notes
- Mirror Replication Agent *Primary Database Guide* for detailed, database-specific information about each database that is supported by the Mirror Replication Agent.
- Mirror Replication Agent *Installation Guide* for information about installing the Mirror Replication Agent software
- The Mirror Replication Agent *Release Bulletin* for last-minute information that was too late to be included in the books

Note A more recent version of the Mirror Replication Agent *Release Bulletin* may be available on the World Wide Web. To check for critical product or document information that was added after the release of the product CD, use the Sybase Product Manuals Web site.

Java environment

The Mirror Replication Agent component requires a Java Runtime Environment (JRE) on the Mirror Replication Agent host machine.

- The Mirror Replication Agent *Release Bulletin* contains the most up-to-date information about Java and JRE requirements.
- Java documentation available from your operating system vendor describes how to set up and manage the Java environment on your platform.

Further information about Java environments can be found at the following URL:

<http://java.sun.com>

Other sources of information

Use the Sybase Getting Started CD, the SyBooks™ CD, and the Sybase Product Manuals Web site to learn more about your product:

- The Getting Started CD contains release bulletins and installation guides in PDF format, and may also contain other documents or updated information not included on the SyBooks CD. It is included with your software. To read or print documents on the Getting Started CD, you need Adobe Acrobat Reader, which you can download at no charge from the Adobe Web site using a link provided on the CD.
- The SyBooks CD contains product manuals and is included with your software. The Eclipse-based SyBooks browser allows you to access the manuals in an easy-to-use, HTML-based format.

Some documentation may be provided in PDF format, which you can access through the PDF directory on the SyBooks CD. To read or print the PDF files, you need Adobe Acrobat Reader.

Refer to the *SyBooks Installation Guide* on the Getting Started CD, or the *README.txt* file on the SyBooks CD for instructions on installing and starting SyBooks.

- The Sybase Product Manuals Web site is an online version of the SyBooks CD that you can access using a standard Web browser. In addition to product manuals, you will find links to EBFs/Maintenance, Technical Documents, Case Management, Solved Cases, newsgroups, and the Sybase Developer Network.

To access the Sybase Product Manuals Web site, go to Product Manuals at <http://www.sybase.com/support/manuals/>.

Sybase certifications on the Web

Technical documentation at the Sybase Web site is updated frequently.

❖ To find the latest information on product certifications

- 1 Point your Web browser to Technical Documents at <http://www.sybase.com/support/techdocs/>.
- 2 Click Certification Report.
- 3 In the Certification Report filter select a product, platform, and timeframe, and then click Go.
- 4 Click a Certification Report title to display the report.

❖ **To find the latest information on component certifications**

- 1 Point your Web browser to Availability and Certification Reports at <http://certification.sybase.com/>.
- 2 Either select the product family and product under Search by Base Product, or select the platform and product under Search by Platform.
- 3 Select Search to display the availability and certification report for the selection.

❖ **To create a personalized view of the Sybase Web site (including support pages)**

Set up a MySybase profile. MySybase is a free service that allows you to create a personalized view of Sybase Web pages.

- 1 Point your Web browser to Technical Documents at <http://www.sybase.com/support/techdocs/>.
- 2 Click MySybase and create a MySybase profile.

Sybase EBFs and software maintenance

❖ **To find the latest information on EBFs and software maintenance**

- 1 Point your Web browser to the Sybase Support Page at <http://www.sybase.com/support>.
- 2 Select EBFs/Maintenance. If prompted, enter your MySybase user name and password.
- 3 Select a product.
- 4 Specify a time frame and click Go. A list of EBF/Maintenance releases is displayed.

Padlock icons indicate that you do not have download authorization for certain EBF/Maintenance releases because you are not registered as a Technical Support Contact. If you have not registered, but have valid information provided by your Sybase representative or through your support contract, click Edit Roles to add the “Technical Support Contact” role to your MySybase profile.

- 5 Click the Info icon to display the EBF/Maintenance report, or click the product description to download the software.

Style conventions

The following style conventions are used in this book:

- In a sample screen display, commands that you should enter exactly as shown appear like this:

```
ra_version
```

- In the regular text of this document, variables or user-supplied words appear like this:

Specify the `value` option to change the setting of the configuration parameter.

- In a sample screen display, variables or words that you should replace with the appropriate value for your site appear like this:

```
resume connection to pds.pdb
```

where *pds* and *pdb* are the variables you should replace.

- In the regular text of this document, names of programs, utilities, procedures, and commands appear like this:

Use the `pdb_init` command to initialize the primary database.

- In the regular text of this document, names of database objects (tables, columns, stored procedures, etc.) appear like this:

Check the `price` column in the `widgets` table.

- In the regular text of this document, names of datatypes appear like this:

Use the `date` or `datetime` datatype.

- In the regular text of this document, names of files and directories appear like this:

Log files are located in the `$SYBASE/MA-15_0/inst_name/log` directory.

Syntax conventions

The following syntax conventions are used in this book:

Table 1: Syntax conventions

Key	Definition
{ }	Curly braces indicate that you must choose at least one of the enclosed options. Do not type the braces when you enter the command.
[]	Brackets mean that choosing one or more of the enclosed options is optional. Do not type the brackets when you enter the command.
()	Parentheses are to be typed as part of the command.
	The vertical bar means you can select only one of the options shown.
,	The comma means you can choose as many of the options shown as you like, separating your choices with commas that you type as part of the command.

In reference sections of this document, statements that show the syntax of commands appear like this:

```
ra_config [param [, value]]
```

The words *param* and *value* in the syntax are variables or user-supplied words.

The following character case conventions are used in this book:

- All command syntax and command examples are shown in lowercase. However, Mirror Replication Agent command names are *not* case sensitive. For example, RA_CONFIG, Ra_Config, and ra_config are equivalent.
- Names of configuration parameters are case sensitive. For example, Scan_Sleep_Max is not the same as scan_sleep_max, and the former would be interpreted as an invalid parameter name.
- Database object names are *not* case sensitive in Mirror Replication Agent commands. However, if you need to use a mixed-case object name in a command (to match a mixed-case object name in the primary database), you must delimit the object name with quote characters. For example:

```
pdb_get_tables "TableName"
```

This document is available in an HTML version that is specialized for accessibility. You can navigate the HTML with an adaptive technology such as a screen reader, or view it with a screen enlarger.

Mirror Activator and the HTML documentation have been tested for compliance with U.S. government Section 508 Accessibility requirements. Documents that comply with Section 508 generally also meet non-U.S. accessibility guidelines, such as the World Wide Web Consortium (W3C) guidelines for Web sites.

Character case conventions

Accessibility features

The online help for this product is also provided in HTML, which you can navigate using a screen reader.

Note You might need to configure your accessibility tool for optimal use. Some screen readers pronounce text based on its case; for example, they pronounce ALL UPPERCASE TEXT as initials, and MixedCase Text as words. You might find it helpful to configure your tool to announce syntax conventions. Consult the documentation for your tool.

For information about how Sybase supports accessibility, see Sybase Accessibility at <http://www.sybase.com/accessibility>. The Sybase Accessibility site includes links to information on Section 508 and W3C standards.

For a Section 508 compliance statement for Mirror Activator, see Sybase Accessibility at <http://www.sybase.com/detail?id=1028493>.

If you need help

Each Sybase installation that has purchased a support contract has one or more designated people who are authorized to contact Sybase Technical Support. If you cannot resolve a problem using the manuals or online help, please have the designated person contact Sybase Technical Support or the Sybase subsidiary in your area.



Introduction to Mirror Activator

This chapter provides an overview of replication solutions for disaster recovery, introduces the Mirror Activator solution and the Mirror Replication Agent component, and explains how Mirror Activator works.

Topic	Page
Disaster recovery options	1
The Mirror Activator solution	4
How Mirror Activator works	5

Disaster recovery options

Unfortunately, effective disaster recovery solutions can be viewed as “expensive insurance” because of the high total cost of ownership (TCO) and low return on investment (ROI) that is typically associated with them.

Upper-tier disaster recovery solutions require a means to replicate mission-critical data from a primary site to a remote standby site. The following sections describe two replication alternatives for disaster recovery: *disk* replication and *transaction* replication.

Disk replication

Disk replication (or disk mirroring) systems replicate the contents of a disk volume or file system from a primary site to a standby site.

Benefits of disk replication

The main benefits of disk replication are:

- Redundancy of primary disk devices at a remote standby site
- Zero or near-zero data loss, particularly with synchronous replication

Disadvantages of disk replication

The benefits of disk replication come at a relatively high cost, and there are significant disadvantages and gaps in the protection that disk replication provides:

- A substantial cost of disk replication results from forcing standby system resources to go offline for periodic updates.

Disk replication requires exclusive write control of mirror devices at the standby site, which conflicts with the DBMS requirement for exclusive device write control, even when client applications cannot change data.

To avoid keeping standby systems completely idle or offline until a failover, local disk replication must be implemented at the standby site to make periodic “snapshots” of mirror devices available to the standby systems.

- Standby system resources are hardware-dependent.

Disk replication is device-based, sending data from a primary device in blocks (or pages) to a mirror device. Hardware and operating systems at the primary site must be duplicated at the standby site, and they must be identical to the primary site configuration.

- Data integrity (transactional consistency) between primary and standby databases cannot be guaranteed.

Disk replication updates mirror devices by block (or page) boundaries, with no knowledge of transaction boundaries. Because a single transaction can change several blocks, on several devices, the standby database can be corrupted if transmission from the primary site is interrupted before all of the affected blocks (on all of the affected devices) are received at the standby site.

- Disk replication provides no protection from disk corruptions at the primary site, which are replicated block-for-block to mirror devices at the standby site.
- Disk replication requires high network bandwidth for synchronous replication with acceptable application response time, particularly for databases with high transaction volumes.

Transaction replication

Transaction replication systems read the transaction log of the primary database, convert the log records into equivalent SQL commands, and then apply the SQL to a standby database.

Benefits of transaction replication

The main benefits of transaction replication are:

- Data integrity (transactional consistency) between primary and standby databases is guaranteed.

Transaction replication is *logical* replication. It is based on the transaction log of the primary database, so it follows all of the data integrity “rules” of the database.

- Standby databases are always available for decision support and reporting applications, with no downtime required by the transaction replication system.

Transaction replication requires the standby database to be continuously online, so it can apply replicated transactions as they arrive in the primary database log. Transaction replication does not require control of any database devices or log devices.

Note Availability of standby system resources increases the ROI on both hardware and the DBMS software required to support disaster recovery.

- Standby system resources are hardware-independent because transaction replication is logical and not device-specific.
- The standby site is protected from disk corruption because transaction replication is based on the primary database transaction log, which is managed at the device level by the primary DBMS.
- Network bandwidth requirements are reduced because:
 - Transactions rolled back in the primary database do not need to be replicated.
 - Transaction replication can encode the replicated transactions and data in a more compact form than the actual log records or raw SQL. This results in more efficient network communication.

Note High network bandwidth can be a substantial operating cost, so reducing the bandwidth requirement lowers the TCO of a disaster recovery solution.

Disadvantages of transaction replication

There are also some disadvantages of transaction replication when used alone for disaster recovery:

- Disaster recovery is provided only for databases, and not for applications or other data stores at the primary site.
- Transaction replication is asynchronous, so:

- Network congestion can increase latency, which can increase the recovery time.

Latency is the time elapsed between committing a transaction at the primary database and committing that transaction at the standby database.

- Some data loss can occur in certain situations.

If the connection to the primary site goes down after a transaction is committed, but before the replication system reads the primary log record, the transaction cannot be replicated.

The Mirror Activator solution

Mirror Activator is a Sybase software solution that allows you to combine the benefits of transaction replication and disk replication, thus eliminating the disadvantages of using either system alone in a disaster recovery situation.

Mirror Activator advantages

Compared to disaster recovery solutions that are based on either disk replication or transaction replication alone, advantages of the Mirror Activator solution are:

- Lower total cost of ownership (TCO)
- Enhanced return on investment (ROI)
- An integrated disaster recovery solution, with the “best of both worlds”

Lower TCO

The Mirror Activator solution provides lower TCO with:

- Reduced network bandwidth requirements, because only the primary log devices need to be mirrored (primary data devices need not be mirrored)
- Hardware-independence for the standby DBMS (both hardware and operating system flexibility)

Enhanced ROI

The Mirror Activator solution provides enhanced and immediate ROI with:

- No downtime required for standby databases (always online and available for client applications, always up-to-date)

Integrated solution benefits

- No idle time required for standby hardware and infrastructure (always available when not used for recovery)
- Mirror Activator provides an integrated disaster recovery solution with:
- Standby databases protected from disk corruption (by logical, not literal, replication)
 - Synchronous replication, with zero data loss *and* guaranteed data integrity (transactional consistency)
 - Complete coverage for databases, as well as non-database systems

How Mirror Activator works

A Mirror Activator system consists of a special variant of the Sybase transaction replication system, which is integrated with a disk replication system (provided by another vendor). The following describes a Mirror Activator system for ASE and Oracle.

ASE

Figure 1-1 shows a typical Mirror Activator system configuration for ASE. Arrows illustrate the flow of mirrored log device data and replicated transactions during normal Mirror Activator system operation, that is, while replicating transactions from the primary database to the standby database.

Figure 1-1: Mirror Activator system for ASE

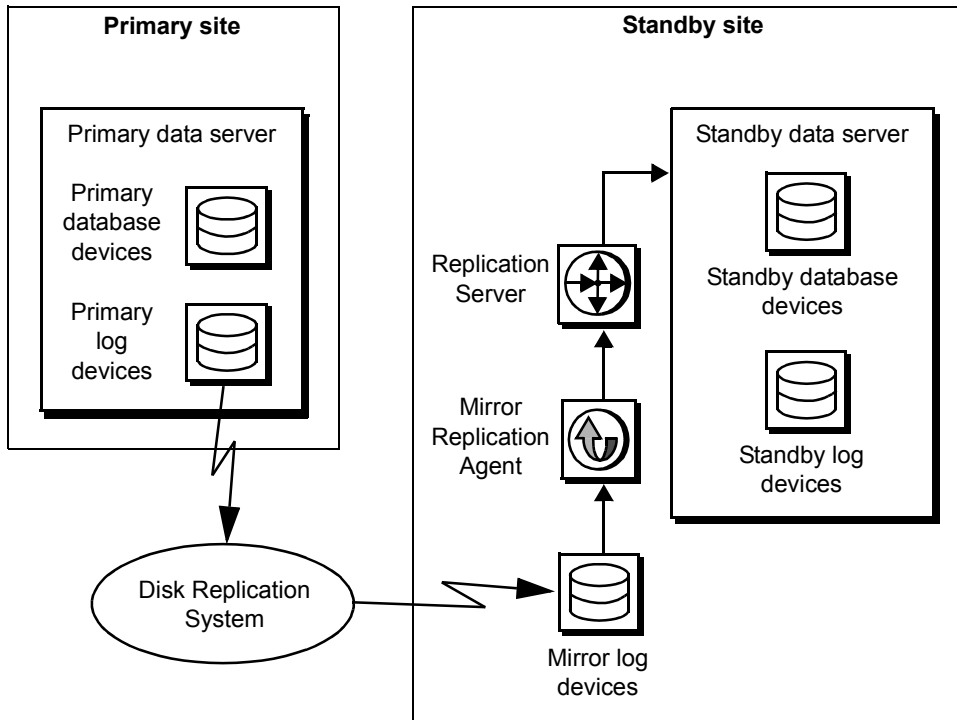

Oracle

Figure 1-2 shows a typical Mirror Activator system configuration for Oracle. Arrows illustrate the flow of mirrored log device data and replicated transactions during normal Mirror Activator system operation, that is, while replicating transactions from the primary database to the standby database.

Figure 1-2: Mirror Activator system for Oracle

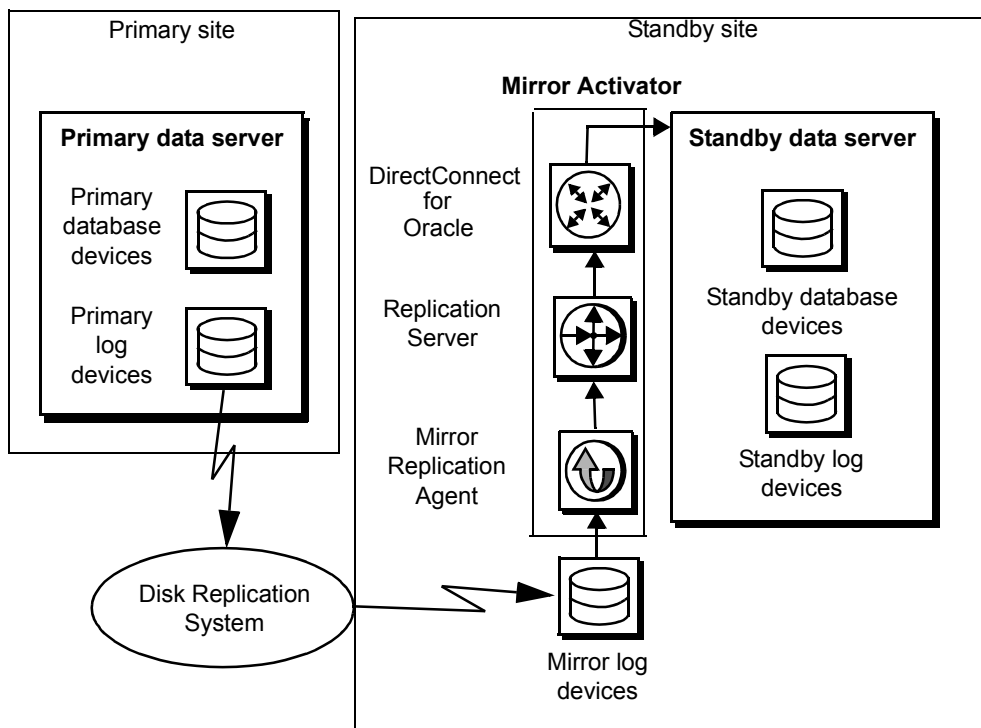

Mirror Activator system components

Note The disk replication system is the Mirror Activator system component that moves log data from the primary site to the standby site. Components of the disk replication system reside at both primary and standby sites.

The following describes the main components of a Mirror Activator system, as shown in Figure 1-1 for ASE, and Figure 1-2 for Oracle:

- Primary database
- Disk replication system
- Mirror log devices
- Mirror Replication Agent

- Replication Server
- DirectConnect for Oracle (for Oracle only)
- Standby database

Primary database	The primary database is the source of transactions that are replicated to the standby database. The primary data server maintains the primary database transaction log, and it controls the primary database log devices.
Disk replication system	The disk replication system replicates data at the device level. It may include a storage area network (SAN), network attached storage (NAS), or disk mirroring/synchronization mechanism, and it may incorporate both hardware and proprietary system software.
Mirror log devices	The mirror log devices are off-site copies of the primary database transaction log devices. They are managed by the disk replication system, which requires exclusive write control of the mirror devices, so they are accessible on a read-only basis.
Mirror Replication Agent	Mirror Replication Agent reads primary database transactions from mirror log devices, and then sends those transactions to Replication Server for distribution to the standby database. The Mirror Replication Agent requires only read access to mirror log devices.
Replication Server	Replication Server receives the replicated transactions from Mirror Replication Agent. Replication Server processes the transactions and converts them into SQL, which it sends to the standby database for processing. When the replicated transactions are processed successfully in the standby database, the standby database is synchronized with the primary database.
DirectConnect for Oracle	<i>For Oracle only.</i> DirectConnect for Oracle consists of a database gateway server that allows you to use the Sybase Open Client and Open Server protocol (such as Replication Server) to connect with non-Sybase data servers, using either the data server's native communications protocol or the standard, ODBC protocol.
Standby database	<p>The standby database is the destination of transactions that are replicated from the primary database. During normal Mirror Activator system operation, the standby database is always online, processing the replicated transactions it receives from the Replication Server.</p> <p>During normal system operation, the Replication Server is the only client allowed to send data-changing transactions to the standby database. All other clients are restricted to read-only database access.</p>

Materializing the standby database

Transaction replication requires a “starting point,” where the primary and standby databases are identical, with the same data and schema. If the standby database is not identical to the primary database, it must be *materialized* before transaction replication begins.

With integrated disk replication, you can materialize the standby database by copying a *snapshot* of the primary data and log devices to the standby site. After the snapshot is received at the standby site, the standby database can be brought online.

Figure 1-3 illustrates how snapshot data moves from devices at the primary site to devices at the standby site, to materialize the standby database.

Figure 1-3: Standby database materialization

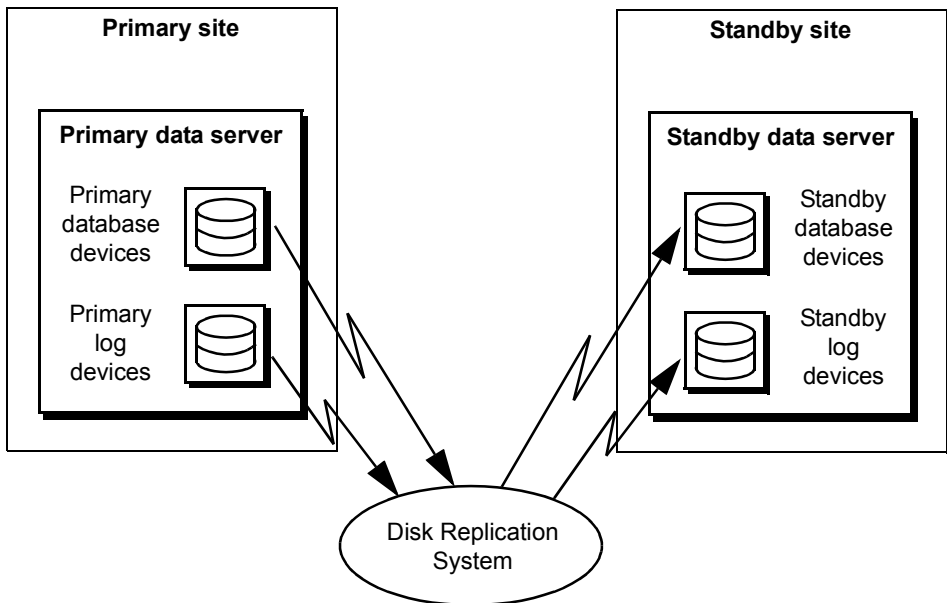

To materialize the standby database, the primary database must be *quiesced*, so that all client applications are locked out of the database, any transactions in progress are frozen, and the primary data and log devices are stabilized.

While the primary database is quiesced, the disk replication system captures a snapshot image of the primary data and log devices. The disk replication system copies the snapshot to the standby data and log devices, which loads the standby database with data and schema that are identical to the primary database.

After materializing the standby database, the disk replication system disconnects from the standby devices, and sends an additional copy of the primary log device snapshot to materialize the mirror log devices. Then, the disk replication system is set to mirror (or synchronously replicate) all subsequent changes on the primary log devices to the mirror log devices, which are the source of all transactions replicated by the Mirror Activator system.

After the snapshot is captured at the primary site, and before primary database access is restored to other client applications, the Mirror Activator system executes a procedure in the primary database to place a *marker* in the transaction log. The Mirror Activator system uses the log marker to identify its “starting point” for transaction replication.

After the marker is recorded in the primary database transaction log, primary database access for client applications can be restored.

Note You can use a similar materialization process to restore the primary database after failover to the standby.

Fault tolerance and automatic recovery

The Mirror Activator system is highly fault-tolerant. It is designed to avoid any single point of failure, and to provide automatic and graceful recovery from any system failure.

During normal Mirror Activator system operation, the disk replication system mirrors the primary database log devices synchronously, which guarantees zero data loss—that is, no data for a completed transaction will be lost.

Device-based queues that the Replication Server maintains guarantee transaction delivery to the standby database, even if network failures occur at the standby site, or if the standby database itself fails.

The Mirror Activator system maintains a *queue ID* in both the Mirror Replication Agent and the Replication Server, which it uses to keep track of the most recent confirmed transaction (successfully replicated) in the standby database. The queue ID allows the Mirror Activator system to automatically recover from system faults, and it prevents either the Mirror Replication Agent or the Replication Server component from becoming a single point of failure.

Introduction to Mirror Replication Agent

Mirror Replication Agent is the Mirror Activator system component that reads primary database transactions from mirror log devices, and sends those transactions to Replication Server for distribution to the standby database.

Mirror Replication Agent is a Java application that runs as a standalone process, independent of any other Mirror Activator system component. It requires a Java Runtime Environment (JRE) on its host platform.

Mirror Replication Agent can reside on the same host as the Replication Server or the standby data server, or it can reside on a machine separate from any other Mirror Activator system component. The Mirror Replication Agent host must have local access to the mirror log devices.

Mirror Replication Agent instances

You must create one instance of the Mirror Replication Agent for each primary database that you want to replicate transactions from. Each Mirror Replication Agent instance is an independent process, with its own instance directories to house its configuration file, system log files, and system data repository.

Mirror Replication Agent components

Mirror Replication Agent consists of a set of components that work together to propagate transactions from the mirror log devices to the Replication Server.

Figure 1-4 shows the flow of transaction data through a Mirror Replication Agent during normal (transaction replicating) operation.

Figure 1-4: Mirror Replication Agent transaction data flow

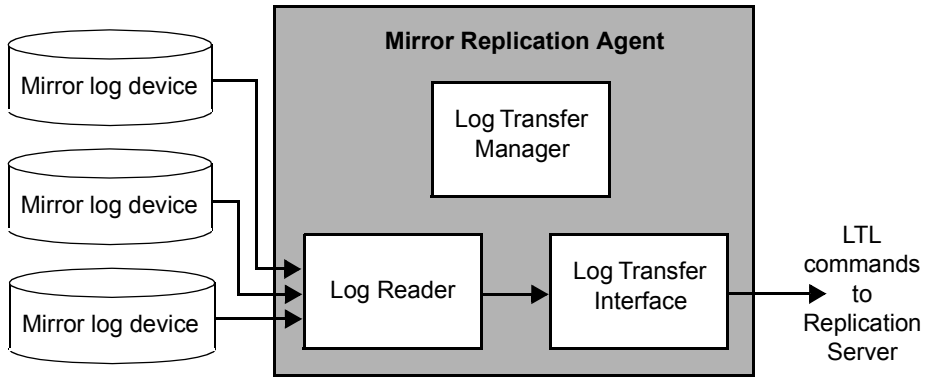

The main Mirror Replication Agent components are:

- Log Reader – reads the primary database transaction log on mirror log devices to retrieve transactions for replication, generates change-set data, and passes change sets to the Log Transfer Interface component.
- Log Transfer Interface (LTI) – processes change-set data from the Log Reader, generates Log Transfer Language (LTL) commands, and sends the LTL commands and data to the Replication Server.
- Log Transfer Manager (LTM) – manages all other components, coordinates their operations and interactions, and processes any errors reported by other components.

Replication Agent System Database

Each Mirror Replication Agent instance uses an embedded database (the Replication Agent System Database, or RASD) to manage its system data repository, which stores information about the primary database schema, mirror log devices, and transaction log metadata.

The system data repository allows Mirror Replication Agent to continue processing transactions from the mirror log devices if the primary database goes offline. The RASD provides database recovery features (such as backup and restore, and software-mirrored devices) to support Mirror Activator system recovery and fault tolerance.

When you create a Mirror Replication Agent instance, the RASD is created automatically. The system data repository is populated with the information that the Mirror Replication Agent needs when you *initialize* the Mirror Replication Agent instance.

Mirror Replication Agent communications for ASE and Oracle

The following describes the Mirror Replication Agent communications for ASE and Oracle.

Mirror Replication Agent communications for ASE

For network connections, Mirror Replication Agent uses the Java Database Connectivity (JDBC) protocol, as implemented by the Sybase JDBC driver, jConnect™ for JDBC™.

Each Mirror Replication Agent instance uses a single instance of jConnect for JDBC to communicate with all Open Client™ and Open Server™ applications, including the Adaptive Server® Enterprise (ASE) primary data server.

Note Mirror Replication Agent uses file or device I/O for access to the mirror log devices.

Figure 1-6 shows how Mirror Replication Agent communicates with other Mirror Activator system components.

Figure 1-5: Mirror Replication Agent communications for ASE

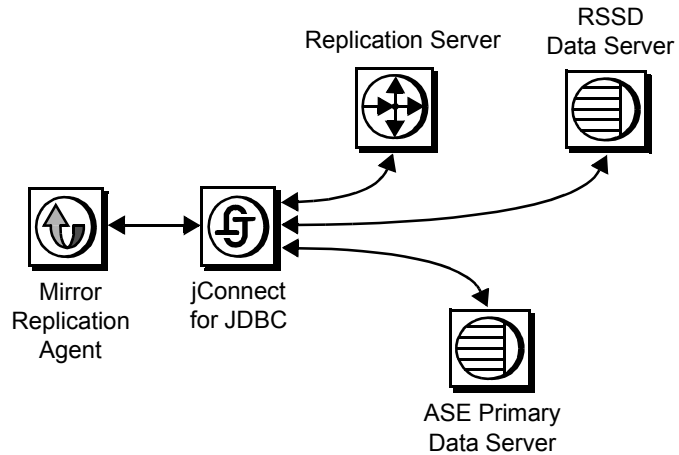

During normal operation (while replicating transactions), Mirror Replication Agent maintains continuous connections with the following Mirror Activator system components:

- Primary data server
- Replication Server

Mirror Replication Agent maintains a connection with the primary data server to reserve the logscan context, which gives it control of the secondary truncation point in the primary database transaction log.

Depending on its configuration, Mirror Replication Agent may connect to the Replication Server System Database (RSSD) to retrieve replication definitions, which it can use to process the replicated transactions more efficiently.

Mirror Replication Agent communications for Oracle

Mirror Replication Agent uses an Oracle-supplied JDBC driver for all communications with Oracle.

Each Mirror Replication Agent instance uses a single instance of the JDBC driver to communicate with an Oracle primary data server. The Sybase jConnect JDBC driver is used to communicate to all Open Client and Open Server applications.

Note Mirror Replication Agent uses file or device I/O for access to the mirror log devices.

Figure 1-6 shows how Mirror Replication Agent communicates with other Mirror Activator system components.

Figure 1-6: Mirror Replication Agent communications for Oracle

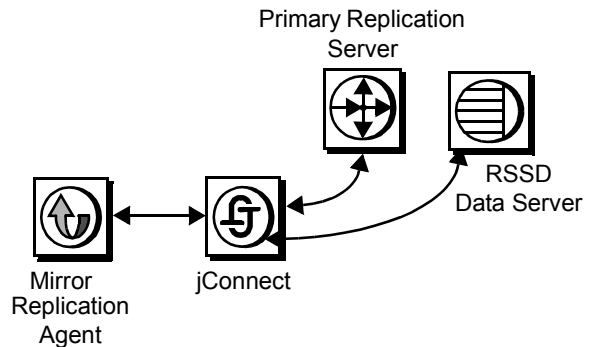

During normal operation (while replicating transactions), Mirror Replication Agent maintains continuous connections with the following Mirror Activator system components:

- Primary database
- Primary Replication Server

Mirror Replication Agent maintains a connection with the primary data server to perform primary database log truncation activities.

Depending on its configuration, Mirror Replication Agent may connect to the RSSD to retrieve replication definitions, which it can use to process the replicated transactions more efficiently.

Managing and monitoring Mirror Replication Agent

You can manage and monitor a Mirror Replication Agent instance by logging in to its administration port, using any Open Client application that implements the Sybase Tabular Data Stream™ (TDS) protocol, such as the interactive SQL utility isql, or SQL Advantage®.

Setting Up and Configuring Mirror Replication Agent

This chapter describes how to set up and configure the Mirror Replication Agent component, and other software components of the Mirror Activator system.

Topic	Page
Setting up the Mirror Activator system	17
Using Mirror Replication Agent utilities	40
Starting the Mirror Replication Agent	61
Using the Mirror Replication Agent administration port	68
Setting up Mirror Replication Agent connectivity	71
Testing network connectivity	80
Marking objects in the primary database	82

Note The procedures in this chapter assume you have already installed Mirror Activator, DirectConnect for Oracle (for Oracle only), and Replication Server software, as described in the Mirror Activator installation guide, the DirectConnect for Oracle installation guide, and the Replication Server® installation and configuration guides for your platform.

Setting up the Mirror Activator system

You have two options when setting up the Mirror Activator system:

- Setting up a *new* Mirror Activator system (that is, using a primary database that was *not* previously configured for a Replication Server warm standby application).

- Converting an existing Replication Server warm standby application to a Mirror Activator system. For more information, refer to the Mirror Replication Agent Primary Database guide.

To set up the Mirror Activator system, you must complete the following high-level tasks:

- Install and configure Mirror Activator system components
- Materialize and set up synchronous replication to devices at the standby site:
 - For a new Mirror Activator system, you must materialize the standby database (data and log devices) and the mirror log devices, and you must set up synchronous replication to the mirror log devices.
 - For a warm standby application that you are converting to a Mirror Activator system, you must materialize and set up synchronous replication to the mirror log devices.

When these tasks are complete, you can start replication with the Mirror Activator system.

Note The setup tasks for some components of the Mirror Activator system require the primary database to be quiesced. To minimize primary database downtime, refer to the appropriate checklist and plan your setup procedures carefully. If you are setting up a new Mirror Activator system, see Table 2-1 on page 20.

Installation and basic configuration

For information about installing Mirror Activator system components and setting them up with a rudimentary configuration, refer to the documentation for each system component.

Sybase software

Sybase provides the following documentation for Mirror Activator system components:

- Mirror Activator *Installation Guide*
- Replication Server installation and configuration guides for your platform
- Enterprise Connect Data Access *Installation Guide* (Oracle installation)

The Replication Server configuration guide for each platform describes the basic configuration required for all Replication Server installations, which is not covered in this document.

Disk replication system and devices

Sybase does not provide hardware or software for disk replication systems. For information about installing and configuring the disk replication system and its related devices, refer to the documentation provided by the disk replication system and/or device component vendor.

Data servers and databases

An existing data server and database (the primary database) is obviously a prerequisite of the Mirror Activator system. Therefore, the tasks associated with installing, configuring, and managing data servers, and designing, creating, and managing databases are not covered in this document.

For information about data servers and databases, refer to ASE and Oracle documentation.

Setting up a new Mirror Activator system

This section describes setup and configuration tasks for the following Mirror Activator system components:

- Primary database
- Mirror Replication Agent
- Replication Server
- ECDA for Oracle (when setting up Mirror Activator for Oracle)
- Standby database

Use the setup and configuration tasks in this section if you are setting up a *new* Mirror Activator system (that is, using a primary database that was *not* previously configured for a Replication Server warm standby application).

Table 2-1 provides a checklist of the tasks required to configure all of the software components and set up a new Mirror Activator system for replication.

The checklist in Table 2-1 assumes that:

- You will perform a snapshot materialization of the standby database, using the disk replication system facilities. See Appendix A, “Materializing Databases in a Mirror Activator system,” for more information.
- You have installed all Mirror Activator components.

- You have already completed all of the tasks described in “Setting up Mirror Replication Agent connectivity” on page 71.

When setting up a new Mirror Activator system, you must perform the tasks in Table 2-1 in the order they are shown. Deviating from this sequence may produce undesired results, requiring the process to be repeated.

Table 2-1: Setup and configuration for a new Mirror Activator system

Task	Description
1	Set up and enable the disk replication system for synchronous replication to the mirror log devices.
2	Set up the disk replication system for snapshot replication to support materialization.
3	Set up the Maintenance User in the primary data server and the primary database.
4	Set up the Maintenance User in the standby data server.
5	<i>For Oracle only:</i> Set up the DDL user in the primary data server.
6	Set up the Replication Server database objects in the primary database.
7	<i>For Oracle only:</i> Set up the Replication Server database objects in the RSSD.
8	Create and configure a Mirror Replication Agent instance.
9	<i>For Oracle only:</i> Set up the ECDA for Oracle to the standby database.
10	Add database connections and Database Replication Definitions and Subscriptions for the primary and standby databases.
	Note For ASE, if using a warm standby database, you must first establish a logical connection.
11	Initialize the Mirror Replication Agent transaction log
12	Shut down the standby data server.
	Note This step is required only when you use snapshot materialization for a standby database.
13	Quiesce the primary database to suspend update activity.
14	Materialize the standby database data and log devices and the mirror log devices at the standby site. Retain synchronous replication to the mirror log devices.

Task	Description
15	Initialize the Mirror Replication Agent using the <code>ra_init</code> command, and set the paths to the mirror log devices. Note You can initialize the Mirror Replication Agent concurrently with materialization.
16	Resume update activity on the primary database, after the device materialization and Mirror Replication Agent initialization are complete.
17	If you use snapshot materialization for a standby database, start the standby data server.
18	Resume the Mirror Replication Agent to put it in Replicating state.
19	Resume the standby database connection in the Replication Server.

The following sections contain detailed procedures for each setup and configuration task.

Set up synchronous replication of log devices

To provide continuous synchronous mirroring of your primary database logs to the standby site, work with your disk replication vendor. The Mirror Replication Agent will require read access to the mirror files while synchronous replication is occurring.

Note Not all disk replication vendors support mounting and access to the mirror files during synchronous replication. Ensure your vendor provides this capability.

Set up snapshot replication for materialization

If using disk replication to materialize your standby database, work with your disk replication vendor to provide on-demand or “snapshot” copies of your primary database and log files. You will also need to work with your primary database vendor to determine exactly what files and steps must be taken to successfully execute the standby database from snapshot file copies.

Note The snapshot log file copies *cannot* be the same target files as the synchronous mirror of the log files used for ongoing replication. Once copied, the snapshot files at the standby site will be owned, and written to, by the standby database. The synchronous mirror of the log files must continue to be active copies of the primary database log files.

Set up the Maintenance User in the primary database

Setting up the Maintenance User involves:

- Adding the Maintenance User login to the primary data server
- Grant appropriate permissions to the Maintenance User login
- Adding the Maintenance User to the primary database

Note Setting up the maintenance user in the primary database assumes that snapshot replication copies this user to the standby database along with the data. If you are using a different materialization technique, the Maintenance User may need to be added directly to the standby database. Regardless of the materialization technique, the Maintenance User must exist and have the appropriate permissions at the standby database after materialization occurs.

To add the Maintenance User to the primary database, follow the steps outlined by your organization's policy for adding new database users, or contact your DBA for assistance in creating a new user.

Set up the Maintenance User in the standby data server

Setting up the Maintenance User involves:

- Adding the Maintenance User login to the standby data server
- Granting the Replication role to the Maintenance User login

You need not add the Maintenance User to the standby database, because when you materialize the standby database, users in the primary database are copied to the standby database.

Set up the DDL User in the primary database (*for Oracle only*)

To replicate DDL commands for Oracle, a unique user must be designated that is granted privileges to execute all replicated DDL commands at the Standby database.

Note This user *must* be different than the Maintenance User previously created.

❖ **To set up the DDL user in the primary database**

- 1 Add the DDL login to the primary data server.
- 2 Grant appropriate permissions to the DDL User login to execute any DDL command to be replicated.

Note Setting up the DDL user in the primary database assumes that snapshot replication will copy this user to the standby database along with the data. If you are using a different materialization technique, the DDL user may need to be added directly to the standby database. Regardless of materialization technique, the DDL user must exist and have the appropriate permissions at the standby database after materialization occurs.

Set up Replication Server database objects

Replication Server requires a few database objects (procedures and tables) in the primary and standby databases, so that it can:

- Place markers in the database transaction log
- Manage the secondary truncation point in the database
- Keep track of successfully replicated transactions
- Replicate stored procedures
- Replicate sequences (Oracle only)

You need not set up Replication Server objects in the standby database, because when you materialize the standby database, Replication Server objects in the primary database are copied to the standby database.

For ASE only

To set up Replication Server objects in the primary database, use the Replication Server *primary database installation script* which is a SQL script named:

- *rsinspri.sql* on Microsoft Windows platforms
- *rs_install_primary.sql* on UNIX platforms

The primary database installation script resides in the Replication Server *scripts* directory (for example, *%SYBASE%\REP-15_0\scripts* on Microsoft Windows platforms).

❖ To set up Replication Server objects in the primary database

- 1 Open an operating system command prompt window on the primary data server host machine.
- 2 At the operating system command prompt, invoke the `isql` utility to execute the primary database installation script in the primary database.

- On Microsoft Windows platforms, enter:

```
isql -Usa -Ppwd -Spds -Dpdb -i rsinspri.sql
```

where:

- *sa* is the System Administrator user login on the primary data server.
- *pwd* is the password for the System Administrator user login.
- *pds* is the name of the primary data server.
- *pdb* is the name of the primary database.

- On UNIX platforms, enter:

```
isql -Usa -Ppwd -Spds -Dpdb -i rs_install_primary.sql
```

where:

- *sa* is the System Administrator user login on the primary data server.
- *pwd* is the password for the System Administrator user login.
- *pds* is the name of the primary data server.
- *pdb* is the name of the primary database.

- 3 Log in to the primary database with system administration privileges.
- 4 Grant permissions on the Replication Server objects in the primary database:

```
grant all on rs_lastcommit to ma_maint
grant execute on rs_get_lastcommit to ma_maint
grant execute on rs_update_lastcommit to public
grant execute on rs_check_repl_stat to public
grant execute on rs_marker to public
```

where:

- *ma_maint* is the name of the Maintenance User in the primary database.

For Oracle only

To set up Replication Server objects in the primary database, use the Replication Server setup for replicate script for the database you are replicating to. The primary database installation script is a SQL script named as follows: *\$\$SYBASE/REP-15_0/scripts/hds_oracle_setup_for_replicate.sql*

Note The scripts in the Replication Server directory have not been updated for this release. Instead, apply the following scripts from the Mirror Replication Agent installation:

```
$$SYBASE/MA-15_0/scripts\oracle\hds_oracle_new_setup_for_replicate.sql
$$SYBASE/MA-15_0/scripts\oracle
\oracle_create_replicate_sequence_proc.sql
```

Set up the Replication Server database objects in the RSSD (for Oracle only)

Replication Server requires changes to the RSSD to support Oracle datatypes.

Note In each script, you must use the RSSD statement to point to the correct RSSD for your Replication Server.

To set up Replication Server changes in the RSSD, execute the following Replication Server scripts against the RSSD database:

```
$$SYBASE/REP-15_0/scripts/hds_oracle_udds.sql
$$SYBASE/REP-15_0/scripts/hds_oracle_funcstrings.sql
$$SYBASE/REP-15_0/scripts/hds_clt_ase_to_oracle.sql
```

```
$SYBASE/REP-15_0/scripts/hds_clt_oracle_to_ase.sql
```

Note The scripts in the Replication Server directory have not been updated for this release. Apply the following additional scripts from the Mirror Replication Agent installation to your RSSD:

```
$SYBASE/MA-15_0/scripts/oracle/hds_oracle_new_udds.sql
```

Create the Mirror Replication Agent instance

After you install the Mirror Replication Agent software, you must create one instance of the Mirror Replication Agent for each primary database that you want to replicate transactions from.

Each Mirror Replication Agent instance is an independent process, with its own instance directories to house its configuration file, system log files, and Replication Agent System Database (RASD). Each Mirror Replication Agent instance manages its own connections to the primary data server, mirror log devices, Replication Server, and RSSD.

When you create a Mirror Replication Agent instance, you must specify:

- A unique instance (server) name
- A unique client socket port number for its administration port

You can create and run more than one Mirror Replication Agent instance on a single host machine, but each instance must have a unique name and a unique port number.

For more information, see “Creating a Mirror Replication Agent instance” on page 46.

Mirror Replication Agent instance directories

The Mirror Replication Agent base directory (*MA-15_0*) and the installation directory (*sybase*) are created when you install the Mirror Replication Agent software.

Note A single installation (on a single host machine) can support multiple Mirror Replication Agent instances. Each instance directory resides under the Mirror Replication Agent base directory created when you install the software.

Set up the ECDA for Oracle to the standby database

For Oracle: If you have not done so already, install ECDA for Oracle and configure a service to the standby database.

Add databases to Replication Server

You must create connections in the Replication Server for the primary and standby databases.

Note You must have “sa” permission in the Replication Server to perform this procedure.

For ASE: Use the Replication Server utility `rs_init` to add connections to Replication Server. The utility `rs_init` does not support non-ASE databases.

❖ **To create database connections in Replication Server (Steps 1 - 3 are for Oracle only)**

- 1 Log in to the Replication Server with a user login that has “sa” permission.
- 2 Create a database connection for the primary database:

```
create connection to pds.pdb
  set error class oracle_error_class
  set function string class
    rs_oracle_function_class
  set username "ma_maint"
  set password "ma_maint_pwd"
  with log transfer on, dsi_suspended
```

where:

- *pds* is the name of the primary data server.
- *pdb* is the name of the primary database.
- *ma_maint* is the Maintenance User login for the primary database.
- *ma_maint_pwd* is the password for the Maintenance User.

Note The *pds* and *pdb* values are usually server host name and Oracle SID.

If the *oracle_error_class* does not exist in your Replication Server, you can create it using the following scripts from the Mirror Replication Agent installation:

- Apply script `$$SYBASE/MA-15_0/scripts/oracle/oracle_create_error_class_1_rs.sql` to Replication Server
- Apply script `$$SYBASE/MA-15_0/scripts/oracle/oracle_create_error_class_2_rssd.sql` to the RSSD
- Apply script `$$SYBASE/MA-15_0/scripts/oracle/oracle_create_error_class_3_rs.sql` to Replication Server

Note The scripts in the Replication Server directory have not been updated for this release. Apply the following additional script from the Mirror Replication Agent installation to your Replication Server, after editing the script to include your primary database connection name:

```
$$SYBASE/MA-15_0/scripts/oracle  
/oracle_create_rs_sequence_repdef.sql
```

3 Create a database connection for the standby database:

```
create connection to sds.sdb  
  set error class oracle_error_class  
  set function string class  
    rs_oracle_function_class  
  set username "ma_maint"  
  set password "ma_maint_pwd"
```

where:

- *sds* is the name of the standby data server.
- *sdb* is the name of the standby database.
- *ma_maint* is the Maintenance User login for the standby database.
- *ma_maint_pwd* is the password for the Maintenance User.

Note If the `oracle_error_class` does not exist in your Replication Server, you can create it using the following scripts from the Mirror Replication Agent installation:

- Apply script `$$SYBASE/MA-15_0/scripts/oracle/oracle_create_error_class_1_rs.sql` to Replication Server
 - Apply script `$$SYBASE/MA-15_0/scripts/oracle/oracle_create_error_class_2_rssd.sql` to the RSSD
 - Apply script `$$SYBASE/MA-15_0/scripts/oracle/oracle_create_error_class_3_rs.sql` to Replication Server
-

The following step applies to ASE and Oracle.

- 4 Add Database Replication Definition and Subscription. Replication Server requires a Database Replication Definition to identify the database objects that are to be replicated from the primary database. A Database Subscription identifies the standby database that will receive the replicated transactions.

To create database replication definitions in Replication Server:

- 1 Log in to the Replication Server with a user login that has “sa” permission.
- 2 Create a database replication definition for the primary database:

```
create database replication definition pds_repdef
with primary at pds.pdb
replicate DDL
go
```

where:

- *pds* is the name of the primary data server.
- *pdb* is the name of the primary database.

To create database replication subscription in Replication Server:

- 1 Log in to the Replication Server with a user login that has “sa” permission.
- 2 Create a database replication definition for the standby database:

```
create subscription pds_sub
for database replication definition pds_repdef
with primary at {pds}.{pdb}
with replicate at {sds}.{sdb}
without materialization
go
```

where:

- *pds* is the name of the primary data server.
- *pdb* is the name of the primary database.
- *sds* is the name of the standby data server.

- *sdb* is the name of the standby database.

Note Replication Server requires a unique function replication definition to support Oracle sequence replication.

Initializing the Mirror Replication Agent transaction log

Mirror Replication Agent uses the native transaction log maintained by the primary database to obtain transactions.

Note *For Oracle only:* The Mirror Replication Agents for Oracle creates user tables in the primary database to support their operation.

Specifying the transaction log object name prefix

You must have set up connectivity between the Mirror Replication Agent instance and the following Mirror Activator system components:

- Primary data server
- Replication Server
- RSSD

Primary databases require you to perform specific setup tasks *before* you can initialize the Mirror Replication Agent transaction log. See the Mirror Replication Agent *Primary Database Guide* to verify that the required setup tasks have been performed for your primary database.

Before you create the Mirror Replication Agent transaction log base objects, you can specify the object name *prefix* string that will be used to name transaction log objects. You can set this prefix string to avoid conflicts with the names of existing database objects in your primary database.

The value of the `pdb_xlog_prefix` parameter is the prefix string used in all Mirror Replication Agent transaction log component names. Use the `ra_config` command to change the value of the `pdb_xlog_prefix` parameter.

Note Mirror Replication Agent uses the value of `pdb_xlog_prefix` to find its transaction log objects in the primary database. If you change the value of `pdb_xlog_prefix` after you create the transaction log, Mirror Replication Agent will not find the transaction log objects that use the old prefix.

❖ **To initialize a Mirror Replication Agent transaction log**

- 1 Log in to the Mirror Replication Agent administration port.
- 2 Define a prefix that uniquely identifies the Mirror Replication Agent transaction log objects that you are creating:

```
ra_config pdb_xlog_prefix, string
```

where *string* is a character string of one to three characters that will be used as a prefix for all database object names of the Mirror Replication Agent transaction log components created in the primary database.

To define a prefix that uniquely identifies the Mirror Replication Agent transaction log objects that you are creating, use the following command:

```
ra_config pdb_xlog_prefix, string
```

where *string* is a character string of one to three characters that will be used as a prefix for all database object names of the Mirror Replication Agent transaction log components created in the primary database.

Note The default value of the `pdb_xlog_prefix` parameter is `ra_`. Unless this string poses a conflict with existing database object names in your primary database, use the default value.

- 3 Initialize the transaction log:

```
pdb_init
```

When you invoke the `pdb_init` command, the Mirror Replication Agent does the following:

- Checks the primary database for compatible settings.
- Generates a SQL script that is run in the primary database. This script creates the Mirror Replication Agent transaction log base objects.

Note *For Oracle only:* By default, `pdb_init` will load the time zone information from Oracle, `installation/oracore/zoneinfo/timezone.dat`. If the file is not accessed by Mirror Replication Agent, you will need to configure the `pdb_timezone_file` configuration property and specify the location of the `timezone.dat` file. For more information, see the Mirror Activator Mirror Replication Agent *Reference Manual*.

For ASE only: When you invoke the `pdb_init` command, the Mirror Replication Agent validates that required settings in the primary database are correctly set to support replication, and creates objects in the primary database. Initializing the primary database does the following:

- Verifies that the primary database configuration is correct for the Mirror Activator system
- Marks the primary database for replication (equivalent to executing `sp_reptostandby` in the primary database)
- Sets the secondary truncation point to the end of the log

Note After you initialize the primary database, you must *not* allow any DDL operations in the primary database before it is quiesced later in the setup procedure.

For Oracle only: The `pdb_init` command validates that the following settings are set to true in the primary database:

- Archiving of redo logs is enabled.
- Supplemental logging of primary key and unique indexes is enabled.

For Oracle only: If any of these settings is not set, the `pdb_init` command returns an error. The following SQL commands can be used to manually validate the settings:

- The result from the following query should be "ARCHIVELOG" when archiving of redo logs is enabled:

```
select log_mode v$database
```

- The results from the following query should both be "TRUE" when supplemental logging of primary key and unique indexes is enabled:

```
select supplemental_log_data_pk,  
       supplemental_log_data_ui from v$database
```

For Oracle only: If any adjustment to these settings is required, follow the instructions in the documentation for your database version on the proper commands to make these changes permanent in your environment.

Note Transaction log base objects must be created before any objects can be marked for replication in the primary database.

- 4 Verify that the Mirror Replication Agent transaction log was created:

```
ra_helpsysinfo
```

When you invoke the `ra_helpsysinfo` command, Mirror Replication Agent returns a list of the transaction log base objects in the primary database if initialization completed successfully. If no information is returned, the transaction log does not exist in the primary database.

Shut down the standby data server

Note *For ASE only:* Skip this procedure if you use the snapshot materialization mount database option for a standby database in Adaptive Server version 12.5.1 or later.

See Appendix A, “Materializing Databases in a Mirror Activator system,” for more information about materialization procedures for the standby database.

Note You must have a System Administrator user role in the standby database to perform this procedure.

❖ To shut down the standby data server

- 1 Log in to the standby database with a System Administrator user role.
- 2 Shut down the standby data server:

```
shutdown
```

Quiesce the primary database

You must quiesce the primary database to suspend update activities until the standby database is materialized and the Mirror Replication Agent is initialized.

Note *For ASE only:* You must have a System Administrator user role in the primary Adaptive Server to perform this procedure.

Any activity that would change the schema in the primary database should not be allowed to take place while Replication Agent is initializing. Select a time when there are no users on the system or quiesce the primary database.

❖ **To quiesce the primary database**

- 1 *For Oracle only:* Quiesce an Oracle database:

```
ALTER SYSTEM QUIESCE RESTRICTED
```

Note Steps 2 and 3 are for ASE only.

- 2 Log in to the primary database server with a System Administrator user role.
- 3 Quiesce the primary database.
 - If you use snapshot materialization for a standby database in Adaptive Server, use the following command to quiesce the primary database:

```
quiesce database MA_setup hold pdb
```

where:

- *MA_setup* is a user-defined tag that identifies the database.
- *pdb* is the name of the primary database.
- If you use the snapshot materialization mount database option for a standby database in Adaptive Server use the following command to quiesce the primary database:

```
quiesce database MA_setup hold pdb  
for external dump to pdb_manifest
```

where:

- *MA_setup* is a user-defined tag that identifies the database.
- *pdb* is the name of the primary database.
- *pdb_manifest* is the name of the manifest file.

Materialize the standby database

Use the disk replication system facilities to perform the following operations:

- Materialize the standby data devices with a snapshot of the primary data devices
- Materialize the standby log devices with a snapshot of the primary log devices
- Materialize the mirror log devices with a snapshot of the primary log devices

- Configure the disk replication system to mirror (synchronously replicate) all changes on the primary log devices to the mirror log devices

See Appendix A, “Materializing Databases in a Mirror Activator system,” for more information.

Refer to the documentation provided by your disk replication system vendor (and/or device vendor) for information about configuring the disk replication system and mirror log devices.

Initialize the Mirror Replication Agent

You must initialize the Mirror Replication Agent instance to populate the RASD with the information it needs about the primary database schema and transaction log devices.

Note This procedure requires the primary database to be quiesced. You can initialize the Mirror Replication Agent concurrently with the standby database materialization.

❖ To initialize the Mirror Replication Agent instance

- 1 Log in to the Mirror Replication Agent administration port.
- 2 Initialize the Mirror Replication Agent instance:

```
ra_init
```

After you initialize the Mirror Replication Agent instance, you may need to alter the log device paths returned by the primary data server during initialization, so that the Mirror Replication Agent can access the mirror log devices.

To determine if you need to alter any default log device path, compare the path returned by the primary data server for each primary log device with the path for the corresponding mirror log device:

- Use the Mirror Replication Agent `ra_helpdevice` command to view the log device paths returned by the primary data server during initialization.
- If necessary, use the Mirror Replication Agent `ra_devicepath` command to alter the default log device path to point to the corresponding mirror log device.

See the Mirror Activator *Mirror Replication Agent Reference Manual* for more information about the `ra_devicepath` and `ra_helpdevice` commands.

When the Mirror Replication Agent is initialized, you can put the Mirror Replication Agent instance in Replicating state. For more information, see Chapter 3, “Administering Mirror Replication Agent,” section “Changing the Mirror Replication Agent state.”

Resume update activity on the primary database

After the standby database materialization and Mirror Replication Agent initialization are complete, release the quiesce to resume update activity on the primary database.

You must *not* resume update activity on the primary database until all of the following operations are complete:

- All standby database data and log devices are materialized.
- All mirror log devices are materialized.
- The disk replication system is configured for synchronous replication from the primary log devices to the mirror log devices.
- The Mirror Replication Agent is initialized, with correct paths defined for all mirror log devices.

❖ To resume update activity on the primary database

- 1 Log in to the primary database with a System Administrator user role.
- 2 Release the quiesce hold on the primary database:

- For ASE:

```
quiesce database MA_setup release
```

where *MA_setup* is a user-defined tag that identifies the suspended database.

- For Oracle:

```
alter system unquiesce
```

Start the standby data server

Issue the appropriate start-up command for your specific database instance.

Resume the Mirror Replication Agent

You must resume the Mirror Replication Agent instance to put it in *Replicating* state, so that it can read the mirror log devices and send replicated transactions to the Replication Server.

❖ To resume the Mirror Replication Agent

- 1 Log in to the Mirror Replication Agent administration port.
- 2 Start replication in the Mirror Replication Agent:

```
resume
```

- 3 Verify that the Mirror Replication Agent instance is in *Replicating* state:

```
ra_status
```

If the Mirror Replication Agent instance is not in *Replicating* state after you invoke the resume command, see Chapter 4, “Troubleshooting Mirror Replication Agent.”

Resume the standby database connection

To start Mirror Activator replication, you must resume the Replication Server connection to the standby database.

Note You must have “sa” permission in the Replication Server to perform this procedure.

❖ To resume the Replication Server standby database connection

- 1 Log in to the Replication Server with “sa” permission.
- 2 Resume the standby database connection to start replication:

```
resume connection to sds.sdb
```

where:

- *sds* is the name of the standby data server.
- *sdb* is the name of the standby database.

If Replication Server fails to begin replication after you invoke the resume connection command, see Chapter 4, “Troubleshooting Mirror Replication Agent,” or refer to the Replication Server *Troubleshooting Guide*.

Mirror Activator configuration requirements

This section describes the configuration requirements for each component.

For detailed setup and configuration procedures:

- See “Setting up Mirror Replication Agent connectivity” on page 71 to configure the Mirror Replication Agent connection parameters.
- See “Setting up a new Mirror Activator system” on page 19 to set up the primary and standby databases, Mirror Replication Agent, and Replication Server in a *new* Mirror Activator system.
- Refer to the documentation provided by your disk replication system vendor (and/or device vendor) to set up and configure the disk replication system and mirror log devices.

Primary database

Configure the primary database as follows:

- Add the Mirror Replication Agent user login name to the primary database, and grant the user appropriate permission to be able to perform tasks necessary to support replication
- Add the Maintenance User login name (as specified in the Replication Server create connection command) to the primary database
- Create and setup Replication Server objects (tables and procedures) in the primary database, with appropriate permissions granted to the Maintenance User name in the primary database
- *For Oracle only:* Configure to enable supplemental logging

Disk replication system

The disk replication system must be configured as follows:

- Make sure it is ready to copy a snapshot image of all primary database data and log devices to the standby database data and log devices, if disk replication will be used to materialize the standby database for a new Mirror Activator system
- Make sure it is ready to copy a snapshot image of all standby database data and log devices to the primary database devices, if disk replication will be used to materialize the primary database for failback
- Make sure it is ready to begin synchronous replication of all primary log devices to the mirror log devices at the standby site

Mirror log devices

Configure the mirror log devices at the standby site as follows:

- Make sure it is ready to receive synchronous replication (or mirroring) of the primary log devices from the disk replication system

- Make sure that Mirror Replication Agent is allowed local, read-only access at the standby site during synchronous replication from primary log devices
- Mirror Replication Agent
- Configure the Mirror Replication Agent instance as follows:
- Make sure that the connection configuration is set correctly for network communications with the primary database, Replication Server, and RSSD
 - Initialize by using the `pdb_init` command to validate that the primary database is prepared for replication.

The `pdb_init` command will validate the primary database as well as setup the Replication Agent system objects in the primary to support procedure replication.
 - Initialize by using the `ra_init` command to set up the RASD
 - Make sure the paths are correctly defined for access to all mirror log devices
- Replication Server
- Configure the Replication Server as follows:
- Use the
- Mirror Replication Agent user login name, with connect source and create object permission granted
 - Identify or create the Mirror Replication Agent user login name for the RSSD
 - Define the database Replication Definition and Subscription for the primary and standby database
 - Apply the Heterogeneous Datatype Support Scripts
- Standby database
- The following list describes the *minimum* standby database configuration required to participate in the Mirror Activator system:
- All the data server options and configuration parameters *exactly match* those of the primary data server.
 - The database name, data and log device configuration, and all database options *exactly match* those of the primary database.
 - Maintenance User login name (as specified in the Replication Server create connection command) added to the standby database, with the required permissions granted.

- Replication Server database objects (tables and procedures) created and set up in the standby database, with appropriate permissions granted to the Maintenance User name in the standby database.
- *For Oracle only:* DDL user login name added to the standby database and granted permissions required to execute replicated DDL commands.

Materialization populates the standby database with all of the contents of the primary database, including the Maintenance User login name and Replication Server database objects (which are required in the primary database). If you use snapshot materialization for the standby database, its name, device configuration, and options must exactly match those of the primary database.

Using Mirror Replication Agent utilities

Two utilities are provided with the Mirror Replication Agent:

- `ma` – starts a Mirror Replication Agent instance, or returns the Mirror Replication Agent software version number.
- `ma_admin` – allows you to create, copy, verify, and delete Mirror Replication Agent instances, or list all verifiable installed Mirror Replication Agent instances on a machine.

Mirror Replication Agent utilities are supplied as batch files for Windows platforms and as shell scripts for UNIX platforms. The utility files reside in the *bin* subdirectory, under the Mirror Replication Agent base directory.

Note On Windows platforms, when you execute a *run* script, you can omit the extension `ma -i my_ma`. However, on UNIX, you must always include the extension `ma.sh -i my_ma`.

You can use the `-help` option with either the `ma_admin` or `ma` command line utility to obtain information about that utility.

For more information, see “Using the command line interface” on page 42.

Preparing to use the utilities

Before you can invoke a Mirror Replication Agent utility, you must:

- Log in to the operating system on the Mirror Replication Agent host machine with a user login that has execute permission in the Mirror Replication Agent installation directory and all subdirectories (for example, the “sybase” user)
- Use the SYBASE environment script to verify that the Sybase environment variables are set

The SYBASE environment script is supplied as a batch file for Microsoft Windows platforms (*SYBASE.bat*) and as a shell script for UNIX platforms (*SYBASE.sh*).

❖ **To set the SYBASE environment**

- 1 Log in to the operating system on the Mirror Replication Agent host machine with a user login that has the appropriate permissions.
- 2 Open an operating system command window.
- 3 At the operating system prompt, navigate to the Mirror Replication Agent installation directory:
 - On Microsoft Windows:

```
cd c:\sybase
```

where *c:\sybase* is the path to the Mirror Replication Agent installation directory.
 - On UNIX:

```
cd /opt/sybase
```

where */opt/sybase* is the path to the Mirror Replication Agent installation directory.
- 4 In the Mirror Replication Agent installation directory, invoke the *SYBASE* environment script:
 - On Microsoft Windows:

```
SYBASE
```
 - On UNIX, for Bourne and Korn shells:

```
SYBASE.sh
```
 - On UNIX, for C-shell:

```
source SYBASE.csh
```

Note On UNIX platforms, you can insert the `source SYBASE.sh` command in the `.login` file for the Mirror Replication Agent administrator (or “sybase” user), so that the SYBASE environment is set automatically when you log in to the Mirror Replication Agent host machine.

Using the command line interface

This section describes how to administer a Mirror Replication Agent instance using the command line interface.

Using the ma utility

The Mirror Replication Agent `ma` utility provides the following functions:

- Starts a specified Mirror Replication Agent instance
- Returns the Mirror Replication Agent software version number

For information about creating a Mirror Replication Agent instance, see “Creating a Mirror Replication Agent instance” on page 46.

To run the `ma` utility, invoke it as a command at the operating system prompt.

Syntax

```
ma [-help | -i inst_name [-state] | -v]
```

Parameters

`-help`

The option that returns command usage information.

Note You can also invoke `ma` with no option specified to return command usage information.

`-i inst_name`

The option that specifies a Mirror Replication Agent instance to start, where *inst_name* is the name of an existing Mirror Replication Agent instance.

`-state`

The keyword that specifies a start-up state for the Mirror Replication Agent instance.

Valid `-state` values are:

- `-admin` starts the Mirror Replication Agent instance in *Admin* state. (This is the default start-up state.)
- `-replicate` starts the Mirror Replication Agent instance in *Replicating* state.

`-v`

The option that returns the Mirror Replication Agent software version number.

Example

To start a Mirror Replication Agent instance named “my_ma” in *Replicating* state, enter the following command at the operating system prompt:

```
ma -i my_ma -replicate
```

For more information, see “Starting the Mirror Replication Agent” on page 61.

For more information, see “Understanding Mirror Replication Agent states” on page 90.

Start-up errors

If the Mirror Replication Agent instance encounters start-up errors:

- On Microsoft Windows platforms, start-up errors are displayed in the operating system command window.
- On UNIX platforms, start-up errors are displayed in the operating system command window and recorded in the Mirror Replication Agent system log.

For more information, see Chapter 4, “Troubleshooting Mirror Replication Agent.”

Using the `ma_admin` utility

The Mirror Replication Agent `ma_admin` utility provides the following functions:

- Creates, copies, deletes, and verifies Mirror Replication Agent instances
- Lists all valid Mirror Replication Agent instances on the Mirror Replication Agent host machine
- Returns the path of the Mirror Replication Agent installation directory
- Creates Mirror Replication instances from parameters in a response file

To run the `ma_admin` utility, invoke it as a command at the operating system prompt

Syntax `ma_admin [option [create options]] [inst_name]`

Note You can also invoke `ma_admin` with no option specified to return command usage information.

Parameters

`-b`

The option that returns the complete path of the Mirror Replication Agent installation directory.

`-c inst_name`

The option that creates a new Mirror Replication Agent instance using the specified name (*inst_name*).

The *inst_name* string must be a valid server name, and unique on the host machine.

When you use the `-c` option, the following options are required:

- `-p`, or
- `-p` and `-f`

When you use the `-f` option, the primary database type specified for the existing Mirror Replication Agent instance is copied to the configuration of the new Mirror Replication Agent instance.

`-p port_num`

The option that specifies a client socket port number for the administration port of the Mirror Replication Agent instance. The *port_num* must be a valid port number, and unique on the Mirror Replication Agent host machine.

When the `-c` option is used, you also have the option of specifying that the configuration of the new Mirror Replication Agent instance should be based on the configuration file for an existing Mirror Replication Agent instance. To do this, use the `-f` option.

`-f old_inst`

The option that copies the configuration of an existing Mirror Replication Agent instance for a new Mirror Replication Agent instance. The *old_inst* string is the name of the existing Mirror Replication Agent instance whose configuration you want to copy for the new Mirror Replication Agent instance.

Note When you use the *-f* option, some configuration parameters are set to default values. For more information, see “Copying a Mirror Replication Agent configuration” on page 56.

-d inst_name

The option that deletes a specified Mirror Replication Agent instance. The *inst_name* string must be the name of an existing Mirror Replication Agent instance.

When you invoke *ma_admin* with the *-d* option, the utility deletes all of the subdirectories associated with the specified instance from the Mirror Replication Agent installation directory.

Note On Microsoft Windows platforms, if any application is accessing a file or directory associated with a Mirror Replication Agent instance when you delete the instance, the open file or directory is *not* deleted. An error message informs you of the file or directory not deleted.

To finish deleting a Mirror Replication Agent instance after a file or directory access conflict on a Microsoft Windows platform, you must:

- Verify that the file or directory is not open in any application
- Manually delete the file or directory

-h

The option that returns command usage information.

-l (lowercase *L*)

The option that lists all verifiable Mirror Replication Agent instances.

-t database

The option that identifies the type of data server that the primary database resides in. The *database* string must be one of the following:

- *ase* – Adaptive Server Enterprise server

- oracle – Oracle database server

Note The *database* value is not case sensitive.

-v inst_name

The option that verifies the complete directory structure for a specified Mirror Replication Agent instance.

The *inst_name* string must be the name of an existing Mirror Replication Agent instance.

Creating a Mirror Replication Agent instance

You can create a Mirror Replication Agent instance at any time after the Mirror Replication Agent software is installed by invoking `ma_admin` with the `-c` option or using the Administrator GUI utility.

The complete syntax is:

```
ma_admin -c new_inst -p port_num [-f old_inst]
```

where:

- *new_inst* is the name of the new Mirror Replication Agent instance you are creating.
- *port_num* is the client socket port number for the administration port of the new Mirror Replication Agent instance.
- *old_inst* is the name of an existing Mirror Replication Agent instance whose configuration you want to duplicate for the new Mirror Replication Agent instance.

You must specify the `-f` option to copy an existing configuration.

For information about creating a Mirror Replication Agent instance based on the configuration of an existing instance, see “Copying a Mirror Replication Agent configuration” on page 56.

Creating Mirror Replication instances using resource files

The `ma_admin` utility provides two command-line parameters that support creating a Mirror Replication Agent instance using a resource file, and validating resource files.

Syntax `ma_admin {-vr res_file | -r res_file}`

Parameters

`-vr res_file`
 Validates the specified resource file (*res_file*), without creating a Mirror Replication Agent instance or making any change in the environment.

`-r res_file`
 Creates a Mirror Replication Agent instance, based on the contents of the specified resource file (*res_file*).

A *resource file* is an ASCII text file that contains configuration information for the Mirror Replication Agent instance to be created by the `ma_admin` utility.

The `ma_admin` parameters in the resource file allow you to specify the following options, in addition to creating a Mirror Replication Agent instance:

- Create the instance user login in the primary data server, and grant all required permissions.
- Start the new instance after it is created.
- Initialize the new instance after it starts.
- Record mirror log device information in the log device repository after the instance is initialized.

Note When you *validate* a resource file with `ma_admin -vr`, no other action is taken, and no Mirror Replication Agent instance is created.

The following sections describe how to use the new `ma_admin` features:

- Creating a new resource file
- Editing a resource file
- Validating a resource file
- Creating an instance with a resource file

Creating a new resource file

A resource file template, named *ase.rs* (for *ASE*) and *oracle.rs* (for *Oracle only*), is provided in the *init* subdirectory of the Mirror Replication Agent installation directory. For example:

```
C:\sybase\MA-15_0\init\ase.rs
```

or

```
C:\sybase\MA-15_0\init\oracle.rs
```

The resource file template contains comments that describe each configuration parameter and its value.

Note Sybase recommends that you validate each resource file *before* you create a Mirror Replication Agent instance using that resource file.

❖ **To create a resource file**

- 1 Copy the resource file template *ma.rs* to another file that you will edit to create the new resource file. For example:

```
cp ase.rs pubs2.rs
```

or

```
cp oracle.rs pubs2.rs
```

where *pubs2.rs* is the name of the new resource file you want to create.

If you have an existing resource file, you can copy that file to create a new resource file, instead of copying the template.

- 2 Use your preferred text editor to edit the resource file copy that you created.

After you create a new resource file, you should validate it. For more information, see “Validating a resource file” on page 49.

Editing a resource file

The *ma_admin* resource file is an ASCII text file that you can edit using any standard text editor.

Resource file contents must conform to the following:

- Configuration parameters for both the Mirror Replication Agent and the *ma_admin* utility must use the following format:

```
param=value
```

where:

- *param* is the name of the configuration parameter.

- *value* is the value of the configuration parameter.

Note Spaces are not allowed before or after the = symbol, or within the *value* string.

- Each ***param=value*** statement must occur on a separate line.
- If a default value exists for a configuration parameter, you can specify the default value with the string `USE_DEFAULT`:

```
param=USE_DEFAULT
```

where *param* is the name of the configuration parameter.

- The following `ma_admin` configuration parameters require a value of yes or no:
 - `create_pds_username`
 - `start_instance`
 - `initialize_instance`

The **yes** value is case-sensitive. Any string other than `[y|Y] [e|E] [s|S]` is interpreted as **no**.

Note Blank lines and lines that begin with the # symbol are ignored in the resource file.

Validating a resource file

When you invoke the `ma_admin` utility with the `-vr` option, the utility validates the specified resource file and returns information about the validation process.

The `ma_admin` utility validates resource files by:

- Verifying uniqueness of the Mirror Replication Agent administration port number and instance name
- Verifying access to the primary data server, Replication Server[®], and RSSD
- Verifying the host name, port number, database name, user login, and password on each server
- Verifying the Replication Server database connection for the primary database

- Verifying that the *pds_username* user has all the required permissions at the primary database
- Verifying that the primary database redo logs are correctly configured
- Verifying access to mirror log devices, if specified in the resource file

If any validation fails, the *ma_admin* utility returns an error message and information about the failure.

You can repeat the validation process as many times as necessary. No entities are changed or created as a result of this process.

Note Sybase recommends that you validate a new resource file *before* you create a Mirror Replication Agent instance using the new resource file.

❖ **To validate a resource file**

- 1 Invoke the *ma_admin* utility, specifying the *-vr* option and the name of the resource file:

```
ma_admin -vr res_file
```

where *res_file* is the name of the resource file you want to validate.

For example, if the resource file is named *pubs2.rs*, enter the following at the command prompt:

```
ma_admin -vr pubs2.rs
```

Validation results are returned as either:

- `Response_file processing completed.`
- or
- `Response_file processing completed with errors.`

If the validation is successful, you can skip step 2, and use the resource file to create a Mirror Replication Agent instance. For more information, see “Creating an instance with a resource file” on page 51.

If the validation encounters errors, continue to step 2.

- 2 Use the following procedure to correct validation errors:
 - a Review the error messages to determine the cause of the failure.
 - b Edit the resource file to correct the appropriate values.
 - c Invoke *ma_admin -vr* again, specifying the name of the resource file.

Repeat this step until the resource file is successfully validated.

Creating an instance with a resource file

When you invoke the `ma_admin` utility with the `-r` option, the utility first validates the specified resource file, as described in “Validating a resource file” on page 49, except:

- If the Mirror Replication Agent primary database user login does not exist in the primary data server, the utility creates it, if specified in the resource file (`create_pds_username=yes`). If the user login does exist in the primary data server but does not have all the required privileges, set `create` to `yes`, to have the utility grant all required permissions.

If the Mirror Replication Agent primary database user login does exist in the primary data server, has all the required privileges, and the resource file specifies that it should be created, the utility returns an error message and does not create the instance. (This error would be caught in the validation process described in “Validating a resource file” on page 49.)

- If the resource file specifies that the new Mirror Replication Agent instance should be initialized (`initialize_instance=yes`), then:
 - The Mirror Replication Agent primary database user login must either exist in the primary data server, or be created by the `ma_admin` utility (`create_pds_username=yes`).
 - The Response file must specify that the Mirror Replication Agent instance should be started (`start_instance=yes`).

Otherwise, the utility returns an error message and does not create the instance.

After validating the resource file successfully, the `ma_admin` utility does the following:

- Creates and configures a Mirror Replication Agent instance, based on the contents of the specified resource file.
- Creates or grants all required privileges for the instance user, if specified in the resource file.
- Starts the new Mirror Replication Agent instance, if specified in the resource file.
- Initializes the new Mirror Replication Agent instance, if specified in the resource file.

- Records mirror log device information in the log device repository, if specified in the resource file.

The utility also returns information about the instance created and the result.

If instance creation fails, the `ma_admin` utility returns an error message and information about the failure.

Note Sybase recommends that you validate a new resource file *before* you create a Mirror Replication Agent instance using the new resource file. For more information, see “Validating a resource file” on page 49.

❖ **To create a Mirror Replication Agent instance**

- Invoke the `ma_admin` utility, specifying the `-r` option and the name of the resource file:

```
ma_admin -r res_file
```

where *res_file* is the name of the resource file.

For example, if the resource file is named *pubs2.rs*, enter the following at the command prompt:

```
ma_admin -r pubs2.rs
```

Results are returned as either:

- `Response_file processing completed.`
- or
- `Response_file processing completed with errors.`

If the instance creation is successful, you can begin using the new Mirror Replication Agent instance.

If the instance creation fails, you may have to:

- Drop the Mirror Replication Agent user from the primary database.
- Delete all files and subdirectories in the instance directory, and delete the instance directory from the Mirror Replication Agent installation directory.
- Edit the resource file to correct the appropriate values.

Note If the instance creation fails, use the following recovery procedure *before* you attempt to create the instance again.

❖ **To recover from instance creation errors**

- 1 If the resource file does *not* specify that the instance user login be created in the primary data server, skip this step and continue with step 2.

If the resource file specifies that the instance user login be created in the primary data server (that is, `create_pds_username=yes`), then:

- a Check the primary database to determine if the instance user was added.
- b Check that the `pds_sa_username` has sufficient privileges to create the instance login at the primary database.
- c Edit the resource file to specify that the instance user login should not be created in the primary data server (`create_pds_username=no`).

Note If the Mirror Replication Agent primary database user login is successfully created before the instance creation fails, you must either:

- Edit the resource file to set the value of the `create_pds_username` parameter to `no`, or
 - Log in to the primary data server and drop the instance login.
-

- 2 Check the Mirror Replication Agent base directory on the Mirror Replication Agent host to determine if a new instance directory was created. The Mirror Replication Agent base directory is:

```
%SYBASE%\MA-15_0
```

where `%SYBASE%` is the Mirror Replication Agent installation directory.

If you do *not* find a new instance directory in the Mirror Replication Agent base directory, skip step 3 and continue with step 4.

If you find a new instance directory in the Mirror Replication Agent base directory, continue with step 3.

- 3 To delete the new instance directory, you have two options:

- Use the `ma_admin` utility to delete the instance:

```
ma_admin -d inst_name
```

where `inst_name` is the name of the instance you want to delete, or

- Use operating system commands to delete all of the files and subdirectories in the new instance directory, and then delete the new instance directory.

- 4 Review the error messages to find the cause of the instance creation failure, and if necessary, edit the resource file to correct the appropriate values.

After editing the resource file, use `ma_admin` to validate the resource file:

```
ma_admin -vr res_file
```

where *res_file* is the name of the resource file.

See “Validating a resource file” on page 49 for more information.

After you complete the recovery procedure, you can retry creating the Mirror Replication Agent instance.

Creating a Mirror Replication Agent using the command line

Use the following procedure to create a Mirror Replication Agent instance using the command line.

Note You must set the SYBASE environment before you invoke the Mirror Replication Agent `ma_admin` utility. For more information see “Preparing to use the utilities” on page 40.

❖ To create a Mirror Replication Agent instance using the command line

- 1 Open an operating system command window on the Mirror Replication Agent host machine.
- 2 At the operating system prompt, navigate to the Mirror Replication Agent *bin* directory:

- On Microsoft Windows platforms:

```
cd %SYBASE%\MA-15_0\bin
```

where `%SYBASE%` is the path to the Mirror Replication Agent installation directory.

- On UNIX platforms:

```
cd $SYBASE/MA-15_0/bin
```

where `$SYBASE` is the path to the Mirror Replication Agent installation directory.

- 3 In the Mirror Replication Agent *bin* directory, invoke the `ma_admin` utility to create a new Mirror Replication Agent instance:

```
ma_admin -c new_inst -p port_num -t database
```

where:

- *new_inst* is the name of the Mirror Replication Agent instance.
- *port_num* is the client socket port number for the administration port of the new instance.

After you invoke `ma_admin`, the operating system prompt returns when the new Mirror Replication Agent instance is created.

- 4 Verify that the Mirror Replication Agent instance was created properly using one of the following methods:

- Invoke `ma_admin` with the `-v` option, and specify the name of the new Mirror Replication Agent instance:

```
ma_admin -v new_inst
```

where *new_inst* is the name of the new Mirror Replication Agent instance.

When you verify a Mirror Replication Agent instance with the `-v` option, the utility verifies the instance by checking for an instance directory with the specified instance name under the Mirror Replication Agent base directory, and checking all of the subdirectories under the Mirror Replication Agent instance directory.

- Invoke `ma_admin` with the `-l` option:

```
ma_admin -l
```

The `-l` option lists all verifiable Mirror Replication Agent instances, which should include the new one you just created.

- As an alternative to using the `ma_admin` utility, you can use operating system commands to verify that the Mirror Replication Agent instance directories were created correctly.

After you create a Mirror Replication Agent instance, you can use the `ma` utility to start the instance so that you can administer and configure it. For more information, see “Starting the Mirror Replication Agent” on page 61.

Note Sybase recommends that you create a user login name and password to replace the default “sa” login and secure access to the administration port, immediately after you create a Mirror Replication Agent instance. For more information, see “Creating the Mirror Replication Agent administrator login” on page 70.

Copying a Mirror Replication Agent configuration

When you create a new Mirror Replication Agent instance, you can copy the configuration of an existing instance by invoking `ma_admin` with the `-c` option and `-f` option.

The complete syntax is:

```
ma_admin -c new_inst -p port_num [-f old_inst]
```

where:

- *new_inst* is the name of the new Mirror Replication Agent instance.
- *port_num* is the client socket port number for the administration port of the new instance.
- *old_inst* is the name of an existing Mirror Replication Agent instance whose configuration you want to copy for the new instance.

If you do not specify the `-f` option, the new Mirror Replication Agent instance is created with a default configuration.

For information about creating a Mirror Replication Agent instance with the default configuration, see “Creating a Mirror Replication Agent instance” on page 46.

Use the following procedure to create a new Mirror Replication Agent instance, based on the configuration of an existing instance.

Note You must set the SYBASE environment before you invoke the Mirror Replication Agent `ma_admin` utility. For more information, see “Preparing to use the utilities” on page 40.

❖ **To copy an existing Mirror Replication Agent instance configuration to a new instance**

- 1 Open an operating system command window on the Mirror Replication Agent host machine.
- 2 At the operating system prompt, navigate to the Mirror Replication Agent *bin* directory.

- On Microsoft Windows platforms:

```
cd %SYBASE%\MA-15_0\bin
```

where *%SYBASE%* is the path to the Mirror Replication Agent installation directory.

- On UNIX platforms:

```
cd $SYBASE/MA-15_0/bin
```

where *\$SYBASE* is the path to the Mirror Replication Agent installation directory.

- 3 In the Mirror Replication Agent *bin* directory, invoke the *ma_admin* utility to create a new Mirror Replication Agent instance whose configuration is based on the configuration of an existing instance:

```
ma_admin -c new_inst -p port_num -f old_inst
```

where:

- *new_inst* is the name of the new Mirror Replication Agent instance.
- *port_num* is the client socket port number for the administration port of the new instance.
- *old_inst* is the name of an existing Mirror Replication Agent instance whose configuration you want to copy for the new instance.

After you invoke *ma_admin*, the operating system prompt returns when the new Mirror Replication Agent instance is created.

- 4 Verify that the Mirror Replication Agent instance was created properly using one of the following methods:

- Invoke *ma_admin* with the *-v* option, and specify the name of the new Mirror Replication Agent instance:

```
ma_admin -v new_inst
```

where *new_inst* is the name of the new Mirror Replication Agent instance.

When you verify a Mirror Replication Agent instance with the `-v` option, the utility verifies the instance by checking for an instance directory with the specified instance name under the Mirror Replication Agent base directory, and checking all of the subdirectories under the Mirror Replication Agent instance directory.

- Invoke `ma_admin` with the `-l` (lowercase L) option:

```
ma_admin -l
```

The `-l` option lists all verifiable Mirror Replication Agent instances, which should include the one you just created.

- As an alternative to using the `ma_admin` utility, you can use operating system commands to verify that the Mirror Replication Agent instance directories were created correctly.

Note When you create a new Mirror Replication Agent instance and copy the configuration of an existing instance, some configuration parameters are set to default values, and they are not copied from the existing configuration.

The values of the following configuration parameters are not copied from an existing configuration:

```
admin_port
log_directory
pds_database_name
pds_datasource_name
pds_host_name
pds_password
pds_port_number
pds_retry_count
pds_retry_timeout
pds_server_name
pds_username
rs_source_db
rs_source_ds
rasd_backup_dir
rasd_database
rasd_trace_log_dir
rasd_tran_log
rasd_tran_log_mirror
asa_port
```

For more information about Mirror Replication Agent configuration parameters, see the Mirror Activator *Mirror Replication Agent Reference Manual*.

After you create a Mirror Replication Agent instance, you can use the `ma` utility to start the instance so that you can administer and configure it.

Note Sybase recommends that you create a user login name and password to replace the default “sa” login and secure access to the administration port, immediately after you create a Mirror Replication Agent instance. For more information see “Creating the Mirror Replication Agent administrator login” on page 70.

Deleting a Mirror Replication Agent instance

You can delete a Mirror Replication Agent instance at any time by invoking `ma_admin` with the `-d` option.

Before you delete a Mirror Replication Agent instance, you should:

- Shut down the Mirror Replication Agent instance, if it is running. For more information, see “Shutting down the Mirror Replication Agent instance” on page 93.
- If the Mirror Replication Agent software is installed on a Microsoft Windows platform, verify that none of the files in the instance subdirectories are open, and that no application or window is accessing the instance subdirectories.

Note You must set the SYBASE environment before you invoke the Mirror Replication Agent `ma_admin` utility. For more information, see “Preparing to use the utilities” on page 40.

❖ To delete a Mirror Replication Agent instance

- 1 Open an operating system command window on the Mirror Replication Agent host machine.
- 2 At the operating system prompt, navigate to the Mirror Replication Agent `bin` directory.
 - On Microsoft Windows platforms:

```
cd %SYBASE%\MA-15_0\bin
```

where *%SYBASE%* is the path to the Mirror Replication Agent installation directory.

- On UNIX platforms, enter:

```
cd $SYBASE/MA-15_0/bin
```

where *\$SYBASE* is the path to the Mirror Replication Agent installation directory.

- 3 In the Mirror Replication Agent *bin* directory, invoke the *ma_admin* utility with the *-d* option to delete a Mirror Replication Agent instance:

```
ma_admin -d inst_name
```

where *inst_name* is the name of the Mirror Replication Agent instance you want to delete.

The following message appears:

```
Are you sure you want to delete the Mirror  
Replication Agent instance inst_name? [y/n]
```

- 4 Enter *y* to delete the Mirror Replication Agent instance.

After the instance is deleted, the operating system prompt returns.

If the instance is running when you invoke *ma_admin* with the *-d* option, the utility returns an error message:

```
Cannot delete Mirror Replication Agent instance  
'inst_name' because it is currently running.
```

To shut down a Mirror Replication Agent instance, log in to its administrative port, and use the *shutdown* command. For more information, see “Shutting down the Mirror Replication Agent instance” on page 93.

- 5 Verify that the Mirror Replication Agent instance was deleted properly using one of the following methods:

- Invoke the *ma_admin* utility with the *-v* option, and specify the name of the deleted Mirror Replication Agent instance:

```
ma_admin -v inst_name
```

where *inst_name* is the name of the deleted Mirror Replication Agent instance.

When you verify a Mirror Replication Agent instance with the `-v` option, the utility looks for an instance directory with the specified instance name under the Mirror Replication Agent base directory, and looks for the correct subdirectories under the Mirror Replication Agent instance directory.

- Invoke the `ma_admin` utility with the `-l` option:

```
ma_admin -l
```

The `-l` option lists all verifiable Mirror Replication Agent instances, which should *not* include the one you just deleted.

- As an alternative to using the `ma_admin` utility, you can use operating system commands to verify that the Mirror Replication Agent instance directories were deleted correctly.

Note If you delete a Mirror Replication Agent instance, Mirror Replication Agent does not unmark any primary database objects marked for replication, nor does it delete its transaction log objects. Before you shut down and delete a Mirror Replication Agent instance, you must unmark primary database objects and delete the transaction log.

Starting the Mirror Replication Agent

To start a Mirror Replication Agent instance, log in to the Mirror Replication Agent host machine with a user name that has execute permission in the Mirror Replication Agent installation directory and all subdirectories (for example, the “sybase” user).

Following are two ways you can start a Mirror Replication Agent instance:

- Invoke the `ma` utility and specify the instance that you want to start, or
- Invoke the `RUN` script for the instance that you want to start.

The `ma` utility and the `RUN` script are batch files on Microsoft Windows and shell scripts on UNIX.

Start-up requirements

Before you can start a Mirror Replication Agent instance and connect to the primary data server, you must set all required variables:

- Add the location of the JDBC driver for the primary database to the CLASSPATH environment variable.
- If the character set on your Mirror Replication Agent is different from the one on your primary database, you need to set the RA_JAVA_DFLT_CHARSET environment variable, so it is the same as that of the primary database. For more information, see the following section.

Setting character sets

In a Mirror Activator system, character set conversions might be required if system components reside on more than one type of platform. For example, if the primary data server host does not support all of the same character sets as the Replication Server host, then character set conversion (between compatible character sets on the two platforms) is required.

Character set problems can produce data inconsistencies between the primary database and the standby database. To avoid character set problems, do one of the following:

- Use the same character set on all servers and platforms in the Mirror Activator system, or
- Use compatible character sets on all servers and platforms in the Mirror Activator system, and configure the Mirror Activator system components to perform the appropriate character set conversions.

Using character set conversions slows performance.

Note Sybase recommends that you use the same character set on *all* servers and platforms in a Mirror Activator system.

Configuring your environment's character set

By default, the Java Virtual Machine (JVM) under which a Mirror Replication Agent instance is running finds your system's default character set. The type of character data that Mirror Replication Agent can handle is determined by the character set, also known as the encoding. Unless you want to override the default character set that the JVM finds on your system, you do *not* need to explicitly set the character set-related environment variable.

To support overriding the default character set, all of the executable scripts (or batch files) in the Mirror Replication Agent */bin* directory, refer to an environment variable named `RA_JAVA_DFLT_CHARSET`. You can set this environment variable to use the character set you want. The character set you specify must be the character set configured on the primary database. For a list of valid Java character sets, see Supported Encodings on the Internationalization page under Documentation for the J2SE 1.4.2 JDK at <http://java.sun.com/j2se/corejava/intl/index.jsp>.

All Mirror Replication Agent instance *RUN* scripts also reference the `RA_JAVA_DFLT_CHARSET` environment variable.

Note If you are using Replication Server to replicate a number of different character sets, you must configure it for UTF8.

You can override the system default character set by doing one of the following:

- Set the value of a system variable named `RA_JAVA_DFLT_CHARSET` in your environment and use the `ra` utility to start the Mirror Replication Agent instance, or
- Set the value of the `RA_JAVA_DFLT_CHARSET` variable in the Mirror Replication Agent instance *RUN* script and use the *RUN* script to start the Mirror Replication Agent instance.

If you start a Mirror Replication Agent instance by invoking the `ra` utility, you can override the value of the `RA_JAVA_DFLT_CHARSET` system variable in your environment to specify the character set.

If you start a Mirror Replication Agent instance by invoking the instance *RUN* script (or batch file), you can edit the instance *RUN* script to specify the default value of `RA_JAVA_DFLT_CHARSET` and specify the character set you want to use.

❖ **To override the system default character set for all instances**

1 Enter a character set value in the *ma* script:

- For Windows, edit the `%SYBASE%\MA-15_0\bin\ma.bat` file.
- For UNIX, edit the `$$SYBASE/MA-15_0/bin/ma.sh` file:

```
RA_JAVA_DFLT_CHARSET=charset
```

where *charset* is the Java-supported encoding.

For example, `ISO8859_1` or `Cp1252` for ISO-1 (also known as Latin-1), and `ISO8859_8` or `Cp1255` for Hebrew.

Note In UNIX, spaces are *not* allowed on either side of the equals sign. For a list of valid Java character sets, see Supported Encodings on the Internationalization page under Documentation for the J2SE 1.4.2 JDK at <http://java.sun.com/j2se/corejava/intl/index.jsp>.

2 Uncomment the following lines of code:

- For Windows:

```
set RA_JAVA_DFLT_CHARSET=charset
```

- For UNIX:

```
RA_JAVA_DFLT_CHARSET=charset  
export RA_JAVA_DFLT_CHARSET
```

❖ **To override the system default character set for a Mirror Replication Agent instance**

• Enter a character set value in the *RUN* script:

- For Windows, edit the `%SYBASE%\MA-15_0\<instance>\RUN_<instance>.bat` script:

```
set RA_JAVA_DFLT_CHARSET=charset
```

- For UNIX, edit the `$$SYBASE/MA-15_0/<instance>/RUN_<instance>.sh` batch file:

```
RA_JAVA_DFLT_CHARSET=charset  
export RA_JAVA_DFLT_CHARSET
```

where *charset* is the Java-supported encoding.

For example, `ISO8859_1` or `Cp1252` for ISO-1 (also known as Latin-1), and `ISO8859_8` or `Cp1255` for Hebrew is supported.

Note In UNIX, spaces are *not* allowed on either side of the equals sign.

For a list of valid Java character sets, see Supported Encodings on the Internationalization page under Documentation for the J2SE 1.4.2 JDK at <http://java.sun.com/j2se/corejava/intl/index.jsp>.

Starting an instance with the `ma` utility

When you start the Mirror Replication Agent using the `ma` utility, you can specify the instance start-up state. If you do *not* specify a start-up state when you invoke the `ma` utility, the Mirror Replication Agent instance starts in its default *Admin* state.

Note You must set the `SYBASE` environment before you invoke the Mirror Replication Agent `ma` utility. See “Preparing to use the utilities” on page 40 for more information.

❖ To start Mirror Replication Agent with the `ma` utility

- 1 Open an operating system command window on the Mirror Replication Agent host machine.
- 2 At the operating system prompt, navigate to the Mirror Replication Agent *bin* directory:
 - On Microsoft Windows platforms:

```
cd %SYBASE%\MA-15_0\bin
```

where `%SYBASE%` is the path to the Mirror Replication Agent installation directory.
 - On UNIX platforms:

```
cd $SYBASE/MA-15_0/bin
```

where `$SYBASE` is the path to the Mirror Replication Agent installation directory.
- 3 In the Mirror Replication Agent *bin* directory, invoke the `ma` utility to start the Mirror Replication Agent instance:

```
ma -i inst_name
```

or

```
ma -i inst_name -state
```

where:

- *inst_name* is the server name of the Mirror Replication Agent instance.
- *state* is the optional keyword for the start-up state:
 - **admin** – starts the Mirror Replication Agent instance in *Admin* state.
 - **replicate** – starts the Mirror Replication Agent instance in *Replicating* state.

For example, to start the Mirror Replication Agent instance named “my_ma” in *Replicating* state, enter:

```
ma -i my_ma -replicate
```

After you start the Mirror Replication Agent instance, you must open another operating system command window to log in to its administration port.

Starting an instance with the RUN script

The *RUN* script is named *RUN_inst_name*, where *inst_name* is the name of the Mirror Replication Agent instance. It is created automatically when the Mirror Replication Agent instance is created.

The *RUN* script invokes the *ma* utility with the appropriate parameter values to start the Mirror Replication Agent instance. You can edit the *RUN* script to specify the start-up state.

Note You do not need to set the SYBASE environment variable before you invoke the *RUN* script, because the *RUN* script sets the SYBASE environment variable before it starts the Mirror Replication Agent instance.

❖ To start with the *RUN* script

- 1 Open an operating system command window on the Mirror Replication Agent host machine.

- 2 At the operating system prompt, navigate to the Mirror Replication Agent instance directory, enter the following:

- On Windows:

```
cd %SYBASE%\MA-15_0\inst_name
```

where:

- *%SYBASE%* is the path to the Mirror Replication Agent installation directory.
 - *inst_name* is the name of the Mirror Replication Agent instance.
- On UNIX:

```
cd $SYBASE/MA-15_0/inst_name
```

where:

- *\$SYBASE* is the path to the Mirror Replication Agent installation directory.
 - *inst_name* is the name of the Mirror Replication Agent instance.
- 3 In the Mirror Replication Agent instance directory, invoke the *RUN* script to start the Mirror Replication Agent instance:

```
RUN_inst_name
```

where *inst_name* is the server name of the Mirror Replication Agent instance.

For example, to start the Mirror Replication Agent instance named “my_ma,” enter:

```
RUN_my_ma
```

Note Because this *RUN* script is generated at the time that the instance is created, the UNIX version does not have the *.sh* extension.

After you start the Mirror Replication Agent instance, you must open another operating system command window to log in to its administration port.

Using the Mirror Replication Agent administration port

When you create a Mirror Replication Agent instance, you specify a client socket port number for its administration port. Client applications use this port to connect to the Mirror Replication Agent.

The administration port allows Open Client (or Open Client-compatible) applications to log in and execute Mirror Replication Agent commands. You can use any Sybase Open Client interface utility (such as `isql` or SQL Advantage®) to connect to the Mirror Replication Agent administration port.

Note Client applications are *not* provided with the Mirror Replication Agent software. The `isql` utility is provided with the Replication Server.

Creating an entry in the interfaces file

In general, Open Client applications (such as `isql`) require an interfaces file to identify available servers, host machines, and client ports. On Windows, the interfaces file is named `sql.ini`; on UNIX, the interfaces file is named `interfaces`.

If you want Open Client applications to be able to connect to the Mirror Replication Agent administration port as they would to any other Open Server application, you must create a server entry for the Mirror Replication Agent in the interfaces file on the Open Client application host machine.

A server entry for a Mirror Replication Agent administration port in an interfaces file appears as follows:

```
[inst_name]
query=protocol,host_name,port_num
```

where:

- `inst_name` is the name of the Mirror Replication Agent instance.
- `protocol` is the network protocol used for the connection.
- `host_name` is the name of the Mirror Replication Agent host machine.
- `port_num` is the client socket port number of the administration port.

For example, to specify an interfaces file entry for a Mirror Replication Agent instance named “my_ma,” using the Microsoft Windows socket protocol, on a host named “my_host,” with client socket port number 10002, you would add the following lines to the interfaces file:

```
[my_ma]
query=NLWNSCK,my_host,10002
```

Some systems require the interfaces file to be in the TLI form. If your system does, you must use a utility (such as `sybtli` or `dsedit`) that edits the interfaces file and saves the result in a form compatible with TLI.

After you create an entry for the Mirror Replication Agent instance in the interfaces file, you can connect to the administration port using any Open Client application that uses that interfaces file.

Logging in to the Mirror Replication Agent using *isql*

This section describes how to use the `isql` interactive SQL utility to log in to the Mirror Replication Agent administration port.

Before you can log in to the Mirror Replication Agent administration port with an Open Client application (such as `isql`), first create a server entry for the Mirror Replication Agent instance in the interfaces file. See “Creating an entry in the interfaces file” on page 68 for more information.

Note The first time you log in to a newly created Mirror Replication Agent instance, use the default administrator login “sa” with no password.

❖ To log in to a Mirror Replication Agent instance

- 1 Open an operating system command window.
- 2 At the operating system prompt, enter the following command:

```
isql -Uusername -Ppassword -Sinst_name
```

where:

- *username* is the Mirror Replication Agent administrator login.
- *password* is the corresponding password.
- *inst_name* is the name of the Mirror Replication Agent instance.

For example, to log in to a new Mirror Replication Agent instance named “my_ma,” enter:

```
isql -Usa -P -Smy_ma
```

After you have successfully logged in to the administration port, you can use Mirror Replication Agent commands to administer the Mirror Replication Agent instance.

Creating the Mirror Replication Agent administrator login

Each Mirror Replication Agent instance has only one administrator login. The default administrator login (`sa`, with no password) is created when the Mirror Replication Agent instance is created.

Note Sybase recommends that you create a new administrator login and password to replace the default “sa” login and secure access to the administration port immediately after you create a Mirror Replication Agent instance. See “Creating the Mirror Replication Agent administrator login” on page 70 for more information.

You can use `ra_set_login` to create (or change) the administrator login for a Mirror Replication Agent instance.

❖ **To create or change the Mirror Replication Agent administrator login**

- 1 Log in to the Mirror Replication Agent instance with the administrator login.

When you log in to the Mirror Replication Agent instance for the first time, use the default administrator login.

- 2 After you log in, enter the following command:

```
ra_set_login admin_user, admin_pw
```

where:

- `admin_user` is the new administrator login name you want to use for this Mirror Replication Agent instance.
- `admin_pw` is the password for the new administrator login.

Note Use the values from items 1e and 1f on the “Installation and Setup Worksheet” in the Mirror Activator *Installation Guide* to specify the Mirror Replication Agent administrator login name and password.

The new login name replaces the current administrator login. The next time you log in to the Mirror Replication Agent instance, use the new administrator login name and password.

Setting up Mirror Replication Agent connectivity

You must set up connectivity between the Mirror Replication Agent instance and the following Mirror Activator system components:

- Primary data server
- Replication Server
- RSSD

Primary databases require you to perform specific setup tasks *before* you can set up connectivity between the Mirror Replication Agent and a primary database.

Note The term “RSSD” in this document refers to both RSSD and ERSSD; any difference will be noted.

Setting up connectivity for the Mirror Replication Agent requires:

- Creating a user login name, with the appropriate authority in the primary data server and the primary database, for the Mirror Replication Agent
- Creating a user login name, with connect source and create object permission in the Replication Server, for the Mirror Replication Agent
- Creating a user login name, with the appropriate authority in the RSSD data server and the RSSD, for the Mirror Replication Agent
- Setting values for the Mirror Replication Agent connection configuration parameters

To record the values of connection configuration parameters for each Mirror Replication Agent instance, use the “Installation and Setup Worksheet” in the Mirror Activator *Installation Guide*.

Creating the primary database user login name

Mirror Replication Agent requires client access to the primary database to acquire information about the database schema and database log devices.

Use the following procedure to set up a user login name in the primary data server and the primary database for the Mirror Replication Agent instance.

Note You must have a System Administrator user role in the primary data server to perform this procedure.

❖ **To create a primary database user login for Mirror Replication Agent**

- 1 Log in to the primary data server with a System Administrator user role.
- 2 Add the Mirror Replication Agent login name to the primary data server, and if necessary, to the primary database.

Refer to the documentation provided by your primary data server vendor for information about the specific commands you need to execute to create the Mirror Replication Agent login name in the primary data server (and, if necessary, in the primary database).

Verify that the new user login name is valid (it can log in to the primary data server and access the primary database).

Creating the Replication Server user login name

Use the following procedure to set up a Replication Server user login name for the Mirror Replication Agent instance.

Mirror Replication Agent requires client access to the Replication Server to send replicated transactions.

Note If the Replication Server and databases were previously configured for a Replication Server warm standby application, the Mirror Replication Agent can use the Replication Server login that was created for the ASE RepAgent thread. For more information, see Chapter 1 of the *Mirror Replication Agent Primary Database Guide*.

Note You must have “sa” permission in the Replication Server to perform this procedure.

❖ **To create a Replication Server user login for Mirror Replication Agent**

- 1 Log in to the Replication Server with a login that has “sa” permission.
- 2 Create the Mirror Replication Agent user login name in the Replication Server:

```
create user ma_rs_user set password ma_rs_pwd
```

where:

- *ma_rs_user* is the Mirror Replication Agent user login name.
- *ma_rs_pwd* is the password for the user login name.

- 3 Grant connect source permission to the Mirror Replication Agent login name:

```
grant connect source to ma_rs_user
```

where *ma_rs_user* is the Mirror Replication Agent user login name.

After you set up the Mirror Replication Agent user login in the Replication Server, verify that the new user login name is valid (it can log in to the Replication Server).

Creating the RSSD user login name

Mirror Replication Agent requires client access to the ERSSD or RSSD to obtain information about replication definitions.

The following sections describe procedures for:

- Setting up the ERSSD user login for Mirror Replication Agent
- Setting up the RSSD user login for Mirror Replication Agent

Refer to the appropriate procedure for your Replication Server configuration.

Setting up the RSSD user login for Mirror Replication Agent

Use the following procedure to set up a user login name for the Mirror Replication Agent instance in an RSSD managed by Adaptive Server.

Note You can configure Replication Server to use an external Adaptive Server® Enterprise (ASE) database to host the RSSD information. By default, the Replication Server uses an embedded RSSD. If your environment requires that an ASE must be used to host the RSSD, these instructions will apply.

You must have a System Administrator user role in the Adaptive Server that manages the RSSD to perform this procedure.

Note See “Setting up the ERSSD user login for Mirror Replication Agent” on page 75 for more information.

❖ To set up the RSSD user login for Mirror Replication Agent

- 1 Log in to the Adaptive Server that manages the RSSD with a System Administrator user role.
- 2 Add the Mirror Replication Agent login name to the RSSD data server:

```
use master
sp_addlogin ma_rssd_user, ma_rssd_pwd, rssid_db
```

where:

- *ma_rssd_user* is the Mirror Replication Agent user login name.
- *ma_rssd_pwd* is the password for the user login name.
- *rssd_db* is the database name of the RSSD.

- 3 Add the Mirror Replication Agent user login name to the RSSD:

```
use rssid_db
sp_adduser ma_rssd_user
```

where:

- *rssd_db* is the database name of the RSSD.

- *ma_rssd_user* is the Mirror Replication Agent user login name.

After you set up the Mirror Replication Agent user login in the RSSD, verify that the new user login name is valid (it can log in to the RSSD data server and access the RSSD).

Setting up the ERSSD user login for Mirror Replication Agent

Use the following procedure to set up a user login name for the Mirror Replication Agent instance in an ERSSD managed by Adaptive Server Anywhere.

You must have the primary user role in the ERSSD (“sa” permission in the Replication Server) to perform this procedure.

Note For more information, see “Setting up the RSSD user login for Mirror Replication Agent” on page 74.

❖ To set up the ERSSD user login for Mirror Replication Agent

- 1 Log in to the ERSSD as the primary user.
- 2 Add the Mirror Replication Agent login name to the ERSSD:

```
grant connect to ma_rssd_user
identified by ma_rssd_pwd
```

where:

- *ma_rssd_user* is the Mirror Replication Agent user login name.
 - *ma_rssd_pwd* is the password for the user login name.
- 3 Give the Mirror Replication Agent user permission to read the Replication Server system tables:

```
grant membership in group rs_systabgroup
to ma_rssd_user
```

where *ma_rssd_user* is the Mirror Replication Agent user login name.

After you set up the Mirror Replication Agent user login in the ERSSD, verify that the new user login name is valid (it can log in to the ERSSD and access the Replication Server system tables).

Setting up the connection configuration parameters

When Mirror Replication Agent connects to another Mirror Activator system component, it uses values stored in its configuration parameters to define the following minimal set of connection properties:

- Server host name
- Port number
- User login name
- User login password

For its connection to the Replication Server, Mirror Replication Agent relies on the values of two additional configuration parameters (`rs_source_db` and `rs_source_ds`) to identify the Replication Server primary database connection in the LTL connect source command.

The Mirror Replication Agent instance must be in *Admin* state to set up connection parameters. In *Admin* state, the instance has no connections established to other replication system components, but it is available to execute administrative commands. For more information, see “Understanding Mirror Replication Agent states” on page 90.

Note The values of the `rs_source_db` and `rs_source_ds` parameters must *exactly match* the database and data server names specified in the `create connection` command for the Replication Server primary database connection. The values are case sensitive.

For more information about the `rs_source_db` and `rs_source_ds` parameters, see the Mirror Replication Agent *Reference Manual*.

To record the values of connection configuration parameters for each Mirror Replication Agent instance, use the “Installation and Setup Worksheet” in the Mirror Activator *Installation Guide*.

Note The Mirror Replication Agent instance must be running before you can set its connection configuration parameter values. See “Starting the Mirror Replication Agent” on page 61 for more information.

❖ To set up connection parameters for the primary database

In the *Admin* state, the Replication Agent instance has no connections established to other replication system components, but it is available to execute administrative commands. The Mirror Replication Agent instance must be in *Admin* state to set up connection parameters.

- 1 Log in to the Mirror Replication Agent administration port, and verify that the Mirror Replication Agent instance is in *Admin* state.

- a Use the following command to verify that the Mirror Replication Agent instance is in *Admin* state:

```
ra_status
```

- b If the instance is not in *Admin* state, use the following command to put it in *Admin* state:

```
suspend
```

- 2 Specify the primary data server host name:

```
ra_config pds_hostname, pds_host
```

where *pds_host* is the network name of the primary data server host machine.

- 3 Specify the primary data server port number:

```
ra_config pds_port_number, NNN
```

where *NNN* is the number of the network port where the primary data server listens for connections.

- 4 Specify the primary database name:

```
ra_config pds_database_name, pdb
```

where *pdb* is the primary database name (ASE), or the Oracle SID (Oracle).

- 5 Specify the primary data server user login name for the Mirror Replication Agent instance:

```
ra_config pds_username, ma_pds_user
```

where *ma_pds_user* is the user login name that the Mirror Replication Agent uses to log in to the primary data server.

- 6 Specify the password for the Mirror Replication Agent user login:

```
ra_config pds_password, ma_pds_pwd
```

where `ma_pds_pwd` is the password for the user login name that the Mirror Replication Agent uses to log in to the primary data server.

After you set up connection configuration parameters for the primary database, you can use the Mirror Replication Agent `test_connection` PDS command to test connectivity between the Mirror Replication Agent and the primary database. See “Testing network connectivity” on page 80 for more information.

❖ To set up connection parameters for the Replication Server

Note If the Replication Server and databases were previously configured for a Replication Server warm standby application, the Mirror Replication Agent must use the same values for its `rs_source_db` and `rs_source_ds` parameters as the ASE RepAgent thread used for its `connect database` and `connect dataserver` parameters. For more information, see Chapter 1 of the Mirror Replication Agent *Primary Database Guide*.

1 Log in to the Mirror Replication Agent administration port, and verify that the Mirror Replication Agent instance is in *Admin* state:

a Use the following command:

```
ra_status
```

b If the instance is not in *Admin* state, use the following command to put it in *Admin* state:

```
suspend
```

2 Specify the Replication Server host name:

```
ra_config rs_hostname, rs_host
```

where `rs_host` is the network name of the Replication Server host machine.

3 Specify the Replication Server port number:

```
ra_config rs_port_number, NNN
```

where `NNN` is the number of the network port where Replication Server listens for connections.

4 Specify the Replication Server character set:

```
ra_config rs_charset, charset
```

where `charset` matches the `RS_charset` value in the Replication Server's *configuration (.cfg)* file. The location of the Replication Server's configuration file is `$$SYBASE/REP-15_0/install/<instance>.cfg`.

- 5 Specify the Replication Server user login name for the Mirror Replication Agent instance:

```
ra_config rs_username, ma_rs_user
```

where *ma_rs_user* is the user login name that the Mirror Replication Agent uses to log in to the Replication Server.

- 6 Specify the user login password for the Mirror Replication Agent instance:

```
ra_config rs_password, ma_rs_pwd
```

where *ma_rs_pwd* is the password for the user login name that the Mirror Replication Agent uses to log in to the Replication Server.

- 7 Specify the primary data server name for the Replication Server primary database connection:

```
ra_config rs_source_ds, pds
```

where *pds* is the primary data server name that the Mirror Replication Agent uses in the LTL connect source command.

- 8 Specify the primary database name for the Replication Server primary database connection:

```
ra_config rs_source_db, pdb
```

where *pdb* is the primary database name that the Mirror Replication Agent uses in the LTL connect source command.

❖ **To set up connection parameters for the ERSSD (or RSSD)**

- 1 Log in to the Mirror Replication Agent administration port, and verify that the Mirror Replication Agent instance is in *Admin* state:

- a Use the following command:

```
ra_status
```

- b If the instance is not in *Admin* state, issue the following command to put it in *Admin* state:

```
suspend
```

- 2 Specify the ERSSD host name:

```
ra_config rssid_hostname, rssid_host
```

where *erssd_host* is the network name of the ERSSD host machine.

- 3 Specify the ERSSD port number:

```
ra_config rssid_port_number, NNN
```

where *NNN* is the number of the network port where the ERSSD server listens for connections.

- 4 Specify the ERSSD database name:

```
ra_config rssid_database_name, rssid_db
```

where *rssd_db* is the database name of the ERSSD.

- 5 Specify the ERSSD user login name for the Mirror Replication Agent instance:

```
ra_config rssid_username, ma_rssid_user
```

where *ma_rssid_user* is the user login name that the Mirror Replication Agent uses to log in to the ERSSD.

- 6 Specify the user login password for the Mirror Replication Agent instance:

```
ra_config rssid_password, ma_rssid_pwd
```

where *ma_rssid_pwd* is the password for the user login name that the Mirror Replication Agent uses to log in to the RSSD.

After you set up connection configuration parameters for the Replication Server and RSSD, you can use the Mirror Replication Agent `test_connection` RS command to test connectivity between the Mirror Replication Agent and the Replication Server and RSSD. For more information, see “Testing network connectivity” on page 80.

Testing network connectivity

Mirror Replication Agent provides a simple means of testing network connections. The `test_connection` command sends a connection request and confirms the network connection to the following servers:

- Primary data server
- Replication Server

- RSSD server (if so configured)

Note If the value of the `use_rssd` configuration parameter is `true`, the `test_connection` command tests Mirror Replication Agent connectivity to the RSSD when it tests connectivity to the Replication Server. If the value of the `use_rssd` configuration parameter is `false`, the `test_connection` command does *not* test Mirror Replication Agent connectivity to the RSSD.

The `test_connection` command returns a failure message if:

- The connection specifications (server name, port number, user login, and so forth) recorded in the Mirror Replication Agent configuration parameters are not correct.
- The Mirror Replication Agent cannot establish a connection to a server because of a network failure.
- The Mirror Replication Agent cannot establish a connection to a server because the server is down.

The `test_connection` command does *not* validate Mirror Replication Agent user login permissions in the primary database. It verifies only that the user login and password specified in the `pds_username` and `pds_password` parameters can log in to the primary data server.

The `test_connection` command does verify that the Mirror Replication Agent user login (specified in the `rs_username` and `rs_password` parameters) has connect source permission in the Replication Server.

For more information, see “Setting up Mirror Replication Agent connectivity” on page 71.

Note You must be in *Admin* state to test network connectivity.

❖ **To verify Mirror Replication Agent connections**

- 1 Log in to the Mirror Replication Agent instance with the administrator login.
- 2 Test Mirror Replication Agent network connections:

```
test_connection
```

This command tests all of the connections from the Mirror Replication Agent instance you logged in to.

Note You can test a specific connection (either the primary data server or the Replication Server) by specifying the connection you want to test.

If the `test_connection` command returns a failure, check the Mirror Replication Agent system log to determine the cause of the failure. You may also need to check the system log of the server associated with the connection to determine the cause of the failure.

See the Mirror Activator *Mirror Replication Agent Reference Manual* for more information about the `test_connection` command.

Marking objects in the primary database

For ASE: Primary database initialization (command `pdb_init`) will verify that the database will be configured with the command `sp_reptostandby pdb, ALL`. This will automatically mark all tables for replication, as well as all DDL commands.

For Oracle: The individual tables to be replicated must be marked, either explicitly using the `pdb_setreptable` command, or automatically during `ra_init` processing when configuration parameter `pdb_automark_tables` is set to true.

Tables, stored procedures, and sequences must be marked for replication and have replication enabled for the object (table, stored procedure, or sequence). LOB columns must have replication enabled, and the table that contains the LOB column must be marked for replication and have replication enabled for that table.

There are five types of objects that can be marked for replication in a primary database:

- Tables
- Stored procedures
- Large-object (LOB) columns
- Database Definition Language (DDL)
- Sequences (Oracle only)

Marking tables in the primary database

For transactions against a table to be replicated, the primary table in the primary database must be marked for replication and replication must be enabled for that table:

- *For ASE:* Tables are already marked for replication, based on the setting of `sp_reptostandby` in the primary database.
- *For Oracle:* The setting of `pdb_convert_datetime` affects the generated results. For a detailed description of the `pdb_convert_datetime` configuration parameter, refer to Chapter 2, “Configuration Parameters” in the Mirror Activator Mirror Replication Agent *Reference Manual*

❖ To mark a table in the primary database

- 1 Log in to the Mirror Replication Agent administration port.
- 2 Use the `pdb_setreptable` command to determine if the table you want to mark is already marked in the primary database:

```
pdb_setreptable pdb_table
```

where *pdb_table* is the name of the table in the primary database that you want to mark for replication.

- If the `pdb_setreptable` command returns information that the specified table is marked and replication is enabled, you need not continue this procedure.
 - If the `pdb_setreptable` command returns information that the specified table is marked but replication is disabled, skip step 3 and go to step 4 to enable replication for the table.
 - If the `pdb_setreptable` command returns information that the specified table is not marked, continue this procedure to mark the table for replication.
- 3 Use the `pdb_setreptable` command to mark the table for replication and specify the name to use for replication:

- Use the following command to mark the table for replication using a replication definition with the same table name:

```
pdb_setreptable pdb_table, mark
```

where *pdb_table* is the name of the table in the primary database that you want to mark for replication.

- Use the following command to mark the table for replication using a replication definition with a different table name:

```
pdb_setreptable pdb_table, rep_table, mark
```

where:

- *pdb_table* is the name of the table in the primary database that you want to mark for replication.
 - *rep_table* is the name of the table in the with all tables named *rep_table* clause in the replication definition for this table.
- When marking a table for replication, you can specify that the table owner's name is sent along with the table name in the LTL. To do this, use the *owner* keyword after the *mark* keyword, as shown in the following example:

```
pdb_setreptable pdb_table, mark, owner
```

where *pdb_table* is the name of the table in the primary database that you want to mark for replication.

If the *pdb_dflt_object_repl* parameter is set to *true* (the default), the table marked for replication with the *pdb_setreptable* command is ready for replication after you invoke the *pdb_setreptable* command successfully, and you can skip step 4 in this procedure.

If the *pdb_dflt_object_repl* parameter is set to *false*, you must enable replication for the table before replication can take place.

- 4 Use the *pdb_setreptable* command to enable replication for the marked table:

```
pdb_setreptable pdb_table, enable
```

where *pdb_table* is the name of the marked table in the primary database for which you want to enable replication.

- 5 Use the *pdb_setreptable* command with the *all* keyword to mark or enable all user tables at once:

```
pdb_setreptable all, {mark|enable}
```

where *mark* or *enable* are the keywords identifying the action that should be taken against all user tables in the database.

After the table is marked and replication is enabled for the table, you can begin replicating transactions that affect data in that table.

Marking stored procedures in the primary database

To replicate invocations of a stored procedure in the primary database, the stored procedure must be marked for replication, and replication must be enabled for that stored procedure.

Note *For Oracle only:* DDL replication must be disabled before marking (or unmarking) a stored procedure.

❖ To mark a stored procedure in the primary database

- 1 Log in to the Mirror Replication Agent administration port.
- 2 Use the `pdb_setrepproc` command to determine if the stored procedure you want to mark is already marked in the primary database:

```
pdb_setrepproc pdb_proc
```

where *pdb_proc* is the name of the stored procedure in the primary database that you want to mark for replication.

- If the `pdb_setrepproc` command returns information that the specified stored procedure is marked and replication is enabled, you need not continue this procedure.
 - If the `pdb_setrepproc` command returns information that the specified stored procedure is marked but replication is disabled, skip step 3 and continue this procedure from step 4 to enable replication for the stored procedure.
 - If the `pdb_setrepproc` command returns information that the specified stored procedure is not marked, continue this procedure to mark the stored procedure for replication.
- 3 Use the `pdb_setrepproc` command to mark the stored procedure for replication and specify the name to use for replication:
 - Use the following command to mark the stored procedure for replication using a function replication definition with the same procedure name:

```
pdb_setrepproc pdb_proc, mark
```

where *pdb_proc* is the name of the stored procedure in the primary database that you want to mark for replication.

- Use the following command to mark the stored procedure for replication using a function replication definition with a different procedure name:

```
pdb_setrepproc pdb_proc, rep_proc, mark
```

where:

- *pdb_proc* is the name of the stored procedure in the primary database that you want to mark for replication.
- *rep_proc* is the name of the stored procedure in the with all procedures named *rep_proc* clause in the function replication definition for this stored procedure.

If the `pdb_dflt_object_repl` parameter is set to `true` (the default), the stored procedure marked for replication with the `pdb_setrepproc` command is ready for replication after you invoke the `pdb_setrepproc` command successfully, and you can skip step 4 in this procedure.

If the `pdb_dflt_object_repl` parameter is set to `false`, you must enable replication for the stored procedure so replication can take place.

- 4 Use the `pdb_setrepproc` command to enable replication for the marked stored procedure:

```
pdb_setrepproc pdb_proc, enable
```

where *pdb_proc* is the name of the marked stored procedure in the primary database for which you want to enable replication.

After the stored procedure is marked and replication is enabled for the stored procedure, you can begin replicating invocations of that stored procedure.

Enabling replication for LOB columns

For transactions that affect a LOB column to be replicated, the table that contains the LOB column must be marked for replication and have replication enabled.

Note *For ASE*: LOB columns are already marked for replication, along with their tables, based on the setting of `sp_reptostandby` in the primary database.

If the value of the `pdb_dflt_column_repl` parameter is set to `true`, all LOB columns in a table have replication enabled automatically when you mark the table (by invoking the `pdb_setreptable` command). If the value of the `pdb_dflt_column_repl` parameter is set to `false`, you must enable replication separately for each LOB column before replication can take place.

Note The default value of the `pdb_dflt_column_repl` parameter is `false`.

❖ **To enable replication for a LOB column in the primary database**

- 1 Log in to the Mirror Replication Agent administration port.
- 2 Use the `pdb_setrepcol` command to determine if replication is already enabled for the LOB column you want to enable replication for in the primary database:

```
pdb_setrepcol tablename, pdb_col
```

where:

- *tablename* is the name of the table that contains the LOB column.
- *pdb_col* is the name of the LOB column in the primary database.

If the `pdb_setrepcol` command returns information that replication is enabled for the specified column, you need not continue this procedure.

If the `pdb_setrepcol` command returns information that replication is not enabled for the specified column, continue this procedure to enable replication for the column.

- 3 Use the `pdb_setrepcol` command to enable replication for the LOB column:

```
pdb_setrepcol tablename, pdb_col, enable
```

where:

- *tablename* is the name of the table that contains the LOB column.
- *pdb_col* is the name of the LOB column in the primary database for which you want to enable replication.

After replication is enabled for the LOB column, you can begin replicating transactions that affect data in that column.

Enabling replication for DDL

For DDL to be replicated, the `pdb_setrepddl` command must be set to enable. If `pdb_setrepddl` is set to enable, all DDL in your primary database is replicated. Also, you must set the `ddl_username` and the `ddl_password`.

Note *For Oracle only:* To replicate DDL:

- Mirror Replication Agent requires a unique user name that will have authority to execute all DDL commands at the standby database.
- Replication Server must have a database-level replication definition with `replicate DDL` set in the definition.

For details about configuration property `ddl_username` and for database-level replication definition, refer to the *Mirror Activator Mirror Replication Agent Reference Manual*.

❖ To enable replication for DDL in the primary database

- 1 Log in to the Mirror Replication Agent administration port.
- 2 Use the `pdb_setrepddl` command without an argument to determine if replication is already enabled for DDL in the primary database:

```
pdb_setrepddl
```

If the `pdb_setrepddl` command returns information that replication is enabled, you do not need to continue this procedure.

If the `pdb_setrepddl` command returns information that replication is not enabled for DDL, continue this procedure to enable replication for DDL.

- 3 Use the `pdb_setrepddl` command to enable replication for DDL:

```
pdb_setrepddl enable
```

After replication is enabled for the DDL, you can begin replicating your primary database.

Administering Mirror Replication Agent

This chapter describes administrative tasks and procedures for the Mirror Replication Agent.

Topic	Page
Determining current Mirror Replication Agent status	89
Shutting down the Mirror Replication Agent instance	93
Starting replication in the Mirror Replication Agent	95
Stopping replication in the Mirror Replication Agent	96
Managing the Replication Agent System Database	107
Identifying replicated transactions and procedures	117
Configuring and tuning the Mirror Replication Agent	144

For information about installing the Mirror Replication Agent software, see the Mirror Activator *Installation Guide*.

For information about setting up the Mirror Activator system, including Mirror Replication Agent, see Chapter 2, “Setting Up and Configuring Mirror Replication Agent.”

Note Although example procedures in this chapter show `isql` as the Open Client application used to log in to the Mirror Replication Agent administration port, you can use any Open Client (or Open Client-compatible) application to do so.

Determining current Mirror Replication Agent status

The Mirror Replication Agent status consists of the current state and activity of the Mirror Replication Agent instance.

❖ **To determine the status of a Mirror Replication Agent instance**

- 1 Log in to the Mirror Replication Agent instance with the administrator login.
- 2 Use the following command to get current status for the Mirror Replication Agent instance:

```
ra_status
```

This command returns the current state of the Mirror Replication Agent instance and any current activity, as shown in the following example:

```
State  Action
-----  -----
ADMIN  Waiting for operator command
(1 row affected)
```

Understanding Mirror Replication Agent states

When a Mirror Replication Agent instance is running, it can be in one of two discrete states:

- *Admin* – the instance has no connections established to other Mirror Activator system components, but it is available to execute administrative commands, such as initializing the instance, changing configuration parameters, and maintaining the RASD. No replication processing occurs when the Mirror Replication Agent instance is in *Admin* state.
- *Replicating* – the instance is performing its normal replication processing—scanning the transaction log on the log devices, processing log records and change-set data, and sending LTL commands to the Replication Server. In *Replicating* state, some administrative commands are not allowed.

Note When the state appears as *Replicating (Waiting at end of log)*, the instance is ready to perform (or continue) its normal replication processing, but the Log Reader component is idle and waiting for additional transactions to be logged.

The default start-up state is *Admin*. The Mirror Replication Agent instance goes to *Admin* state automatically when no start-up state is specified.

The state of a Mirror Replication Agent instance can be changed by either:

- An external event that occurs while the Mirror Replication Agent is processing replicated transactions (for example, a network error on the Replication Server connection), or
- Operator intervention (for example, invoking a command that changes the Mirror Replication Agent state).

From the moment a state-changing event occurs until the Mirror Replication Agent instance is actually in the new state, the instance is said to be “in transition.” During state transition, some administrative commands are ignored.

Admin state

A Mirror Replication Agent instance goes to *Admin* state when:

- The instance is started in its default state.
- The instance is started with the `ma` utility `-admin` option.
- The Mirror Replication Agent `quiesce` or `suspend` command is invoked.
- An unrecoverable error occurs when the instance is in *Replicating* state.

In *Admin* state, the Mirror Replication Agent instance is running, but it has no connection established to the Replication Server (or RSSD, if so configured) or the primary database.

You can perform most administrative tasks while the Mirror Replication Agent instance is in *Admin* state, including changing the value of any Mirror Replication Agent configuration parameter.

Note In *Admin* state, the instance can open a connection to the primary database, if necessary, to process a command that requests results from the primary database.

A Mirror Replication Agent instance may go to *Admin* state from *Replicating* state when a network failure or communication error causes its connection to the Replication Server to be dropped.

When Mirror Replication Agent drops a connection, before it goes to *Admin* state, it attempts to re-establish the connection using the values recorded in its configuration parameters for that connection. If it cannot reconnect to the Replication Server, the Mirror Replication Agent instance goes to *Admin* state.

Replicating state

A Mirror Replication Agent instance goes to *Replicating* state when:

- The instance is started with the `ma` utility `-replicate` option.
- The Mirror Replication Agent `resume` command is invoked.

In *Replicating* state, the Mirror Replication Agent instance maintains a connection to the Replication Server, and its Log Reader component scans the mirror log devices for transactions to replicate.

Normally, when the Mirror Replication Agent instance is in *Replicating* state, it maintains a connection to the primary database to perform log truncation and archiving functions. If it drops the primary database connection (for example, because the primary database goes offline), Mirror Replication Agent logs the event and continues its normal replication processing, scanning the mirror log devices for transactions to replicate.

If the Mirror Replication Agent instance has finished processing all of the records in the transaction log, its state may appear as *Replicating (Waiting at end of log)*. In that case:

- The Log Reader component's log-scanning process "sleeps" according to the values of the `scan_sleep_increment` and `scan_sleep_max` configuration parameters.
- After the Log Transfer Interface (LTI) component finishes processing all of the change sets it received from the Log Reader and sending all of the LTL to the Replication Server, no replication throughput occurs until new replicated transactions appear in the log and the Log Reader scans them.
- The Mirror Replication Agent instance remains in *Replicating* state, unless some other event causes it to go to *Admin* state.

Changing the Mirror Replication Agent state

The state of a Mirror Replication Agent instance indicates its current operational condition, and determines which administrative tasks you can perform.

Generally, there are only two reasons to change the state of a Mirror Replication Agent instance:

- To perform certain administrative or maintenance procedures (change the state from *Replicating* to *Admin*)
- To restore normal replication processing (change the state from *Admin* to *Replicating*), either after an administrative or maintenance procedure, or after recovery from an error

Changing from *Replicating* state to *Admin* state

To change the state of the Mirror Replication Agent instance from *Replicating* to *Admin*, you can use either the `quiesce` or `suspend` command. For more information, see “Stopping replication in the Mirror Replication Agent” on page 96.

For more detailed information about the `quiesce` and `suspend` commands, see the Mirror Activator *Mirror Replication Agent Reference Manual*.

Changing from *Admin* state to *Replicating* state

To change the state of the Mirror Replication Agent instance from *Admin* to *Replicating*, you can use the `resume` command. For more information, see “Starting replication in the Mirror Replication Agent” on page 95.

For more detailed information about the `resume` command, see the Mirror Replication Agent *Reference Manual*.

Getting Mirror Replication Agent statistics

The Mirror Replication Agent records information about the performance of its internal components whenever it is in *Replicating* state. You can use this information to tune Mirror Replication Agent performance or troubleshoot problems.

To get information about Mirror Replication Agent performance, use the `ra_statistics` command. You can also use `ra_statistics` to reset the statistics counters.

Note Each time the Mirror Replication Agent instance goes to *Replicating* state, statistics counters are reset automatically.

For more information about the `ra_statistics` command and Mirror Replication Agent performance statistics, see the Mirror Activator *Mirror Replication Agent Reference Manual*.

Shutting down the Mirror Replication Agent instance

Each Mirror Replication Agent instance can be started and shut down independently of all other components in a Mirror Activator system, and independently of other Mirror Replication Agent instances.

For information about how to start a instance, see “Starting the Mirror Replication Agent” on page 61.

Shutting down the Mirror Replication Agent instance terminates its process on the host machine.

Note You can stop all replication processing in the Mirror Replication Agent without shutting down the instance. For more information, see “Stopping replication in the Mirror Replication Agent” on page 96.

To shut down a Mirror Replication Agent instance, you must log in to the administration port and invoke the shutdown command. The shutdown command gives you two options:

- Normal shutdown – first quiesces the Mirror Replication Agent instance, and then shuts down the instance, terminating its process.
- Immediate shutdown – shuts down the Mirror Replication Agent instance and terminates its process immediately, without first quiescing. To use this method, use the *immediate* keyword when you invoke the shutdown command.

Note If the Mirror Replication Agent instance is in state transition, it ignores the shutdown command with no option (normal shutdown). It does *not* ignore shutdown immediate when it is in any state, including transition from one state to another.

When a Mirror Replication Agent instance is shut down normally, it does the following:

- Stops reading the mirror log devices
- Drops its connection to the primary database (if it is connected)
- Finishes processing any transactions it already has in its internal queues
- Drops its connection to the Replication Server after successfully sending LTL for any transactions in its internal queues
- Terminates its process

❖ **To shut down a Mirror Replication Agent instance**

- 1 Log in to the Mirror Replication Agent instance with the administrator login.

2 Invoke the shutdown command as follows:

- Use the following command to shut down the Mirror Replication Agent instance normally:

```
shutdown
```

- Use the following command to force an immediate shutdown, regardless of the state of the Mirror Replication Agent instance:

```
shutdown immediate
```

This command shuts down and terminates the Mirror Replication Agent instance immediately, without first quiescing.

For more detailed information about the shutdown command, see the Mirror Activator Mirror Replication Agent *Reference Manual*.

Starting replication in the Mirror Replication Agent

When you start replication in the Mirror Replication Agent:

- The Mirror Replication Agent instance opens network connections to the primary database and Replication Server (and the RSSD, if so configured).
- The internal Log Reader and Log Transfer Interface components begin normal replication processing, scanning the transaction log for operations to replicate, and sending replicated transactions to the Replication Server.
- The Mirror Replication Agent instance goes from *Admin* state to *Replicating* state.

When the Mirror Replication Agent instance is in *Replicating* state, it maintains a connection to the Replication Server, and its Log Reader component scans the mirror log devices for transactions to replicate.

The Mirror Replication Agent instance must be running before you can start replication. For more information, see “Starting the Mirror Replication Agent” on page 61.

Note Before you attempt to replicate transactions from a log device, use the checklist in “Setting up the Mirror Activator system” on page 17 to verify that your Mirror Activator system is set up properly.

❖ **To start replication in the Mirror Replication Agent**

- 1 Log in to the Mirror Replication Agent instance with the administrator login.
- 2 Use the following command to start replication:

```
resume
```

After you invoke the resume command, the Mirror Replication Agent instance should go from *Admin* state to *Replicating* state.

- 3 Use the following command to verify that the Mirror Replication Agent instance is in *Replicating* state:

```
ra_status
```

If the Mirror Replication Agent instance does not go to *Replicating* state after you invoke the resume command, see Chapter 4, “Troubleshooting Mirror Replication Agent,” for more information.

For more detailed information about the resume command and how Mirror Replication Agent starts replication processing, see the Mirror Replication Agent *Reference Manual*.

Stopping replication in the Mirror Replication Agent

When you stop replication in the Mirror Replication Agent:

- The internal Log Reader and Log Transfer Interface components stop their normal replication processing.
- Any open connections to the primary database are released, and the connection to the Replication Server is dropped.
- The Mirror Replication Agent instance goes from *Replicating* state to *Admin* state.

When the Mirror Replication Agent instance is in *Admin* state, it is running and available to execute administrative commands, but it does not maintain connections to the primary database and Replication Server (and RSSD, if so configured), and it does not process replicated transactions.

Some administrative tasks require the Mirror Replication Agent instance to be in *Admin* state. In a normal operating Mirror Activator system, you must stop replication in the Mirror Replication Agent to perform those tasks.

There are two ways to stop replication in the Mirror Replication Agent:

- Quiesce the Mirror Replication Agent instance to stop replication gracefully. For more information, see “Quiescing the Mirror Replication Agent” on page 97.
- Suspend the Mirror Replication Agent instance to stop replication immediately. For more information, see “Suspending the Mirror Replication Agent instance” on page 98.

Quiescing the Mirror Replication Agent

Quiescing the Mirror Replication Agent instance stops its replication processing gracefully, ensuring that all transactions from the log have been read and sent to the Replication Server:

- The Log Reader component stops reading operations from the transaction log as soon as the end of the last log file has been reached. It continues to send change-set data to the Log Transfer Interface component until it finishes processing the last operation it scanned from the log.
- The Log Transfer Interface component stops sending LTL commands to the Replication Server as soon as it finishes processing the last change set it received from the Log Reader.
- When the Log Transfer Interface component is finished processing its input queue and sending the resulting LTL, the Mirror Replication Agent instance releases all of its connections to the primary database (if any are open), and drops its connection to the Replication Server (and RSSD, if connected).
- The Mirror Replication Agent instance goes from *Replicating* state to *Admin* state.

❖ To quiesce a Mirror Replication Agent instance

- 1 Log in to the Mirror Replication Agent instance with the administrator login.
- 2 Use the following command to quiesce the Mirror Replication Agent:

```
quiesce
```

After you invoke the `quiesce` command, the Mirror Replication Agent instance should go from *Replicating* state to *Admin* state.

- 3 Use the following command to verify that the Mirror Replication Agent instance is in *Admin* state:

```
ra_status
```

Note If the internal queues are full and the primary database is still recording new activity to the log files when you invoke the quiesce command, the quiesce processing may take a while to complete, and there may be a delay before the Mirror Replication Agent instance completes the transition to *Admin* state.

For more detailed information about the quiesce command and Mirror Replication Agent quiesce processing, see the Mirror Replication Agent *Reference Manual*.

Suspending the Mirror Replication Agent instance

Suspending the Mirror Replication Agent instance stops its replication processing immediately:

- The Log Reader component stops scanning the transaction log immediately, and the Log Transfer Interface component stops sending LTL commands to the Replication Server immediately.
- All data in the Mirror Replication Agent internal queues (input and output queues of the Log Reader and Log Transfer Interface components) is flushed without further processing.
- The Mirror Replication Agent instance releases all of its connections to the primary database (if any are open), and drops its connection to the Replication Server (and RSSD, if connected).
- The Mirror Replication Agent instance goes from *Replicating* state to *Admin* state.

❖ To suspend a Mirror Replication Agent instance

- 1 Log in to the Mirror Replication Agent instance with the administrator login.
- 2 Use the following command to suspend the Mirror Replication Agent:

```
suspend
```

After you invoke `suspend`, the Mirror Replication Agent instance should go from *Replicating* state to *Admin* state.

- 3 Use the following command to verify that the Mirror Replication Agent instance is in *Admin* state:

```
ra_status
```

For more detailed information about the suspend command, see the Mirror Replication Agent *Reference Manual*.

Managing the Mirror Replication Agent transaction log

This section describes transaction log administration and maintenance procedures for the following Mirror Replication Agent variants:

- Mirror Replication Agent for ASE
- Mirror Replication Agent for Oracle

Mirror Replication Agent for ASE

The Mirror Replication Agent for ASE uses the native database transaction log to capture replicated transactions. The Mirror Replication Agent maintains a connection with the primary data server to reserve the logscan context, which gives it control of the secondary truncation point in the primary database transaction log.

Mirror Replication Agent for Oracle

The Mirror Replication Agent for Oracle uses the native Oracle log to capture replicated transactions. The transaction log objects it creates in the primary database facilitate stored procedure replication. These database objects require no routine maintenance.

Administration tasks

The following sections describe each Mirror Replication Agent transaction log administration and maintenance task in detail:

- Initializing the Mirror Replication Agent transaction log
- Forcing transaction log removal
- Removing the Mirror Replication Agent transaction log
- Truncating the Mirror Replication Agent transaction log
- Backing up Mirror Replication Agent objects in the primary database

Initializing the Mirror Replication Agent transaction log

Before you can initialize a transaction log, the Mirror Replication Agent instance must be running, and connectivity to the primary database must be established. See “Starting the Mirror Replication Agent” on page 61 and “Setting up Mirror Replication Agent connectivity” on page 71 for more information.

❖ **To initialize a Mirror Replication Agent transaction log in the primary database**

- 1 Log in to the Mirror Replication Agent instance with the administrator login.
- 2 Use the following command to determine if a transaction log associated with this Mirror Replication Agent instance already exists in the primary database:

```
ra_helpsysinfo
```

If a transaction log does not exist, the `ra_helpsysinfo` command returns no information about transaction log objects. Continue this procedure to create a transaction log in the primary database.

Note The `ra_helpsysinfo` command looks for transaction log components based on the value of the `pdb_xlog_prefix` configuration parameter. If the value of the `pdb_xlog_prefix` parameter changed *after* a transaction log was created, the `ra_helpsysinfo` command will not find the previously created transaction log objects.

If a Mirror Replication Agent transaction log exists in the primary database, the `ra_helpsysinfo` command returns a list of the transaction log objects. For Mirror Replication Agent for Oracle, if replication has *not* been initialized, it returns the Oracle database instance name.

If a transaction log exists for the Mirror Replication Agent instance, you do not need to complete this procedure.

- 3 If you want to use a particular string for the database object name prefix of the transaction log components, use the `ra_config` command to set the value of the `pdb_xlog_prefix` parameter:

```
ra_config pdb_xlog_prefix, XXX
```

where *XXX* is a one- to three-character string that will be the new value of the `pdb_xlog_prefix` parameter, and the prefix string used in the database object names of transaction log components when the transaction log is created. The default value of the `pdb_xlog_prefix` parameter is `ra_`.

Note The value of the `pdb_xlog_prefix_chars` parameter specifies the non-alphabetic characters that are allowed in the prefix string (the value of the `pdb_xlog_prefix` parameter). The primary data server may restrict the characters that can be used in database object names.

You can also use `ra_config` to determine the current value of the `pdb_xlog_prefix` parameter:

```
ra_config pdb_xlog_prefix
```

When you invoke `ra_config` and specify a configuration parameter with no value, it returns the current value of that parameter.

- 4 Use the `pdb_init` command to initialize the Mirror Replication Agent transaction log:

```
pdb_init
```

Note When you invoke `pdb_init`, the command returns an error message if a transaction log (using the prefix string currently specified in the `pdb_xlog_prefix` parameter) already exists in the primary database.

When you invoke the `pdb_init` command, the Mirror Replication Agent does the following:

- Checks the primary database for compatible settings.
- Generates a SQL script that is run in the primary database. This script creates the Replication Agent transaction log base objects.

For Replication Agents that use a RASD, the RASD is initialized with information from the primary database.

Note You can configure the Mirror Replication Agent to generate the script—but not execute it—by setting the value of the `pdb_auto_run_scripts` parameter to `false` *before* you invoke the `ra_init` command. To complete the transaction log creation, you must manually execute that script in the primary database.

If the log-creation script executes successfully, the script is stored in a file named *partinit.sql* in the *scripts/xlog/installed* directory.

If the log-creation script does *not* execute successfully, the primary database is not changed, and the script is stored in a file named *partinit.sql* in the *scripts/xlog* directory.

Check the primary database error log to determine why the log-creation script did not execute successfully. See Chapter 4, “Troubleshooting Mirror Replication Agent,” for more information.

Removing the Mirror Replication Agent transaction log

The Mirror Replication Agent instance must be running in *Admin* state to remove the transaction log. See “Starting the Mirror Replication Agent” on page 61 for more information.

❖ **To remove the Mirror Replication Agent transaction log from the primary database**

- 1 Log in to the Mirror Replication Agent instance with the administrator login.
- 2 Use the `ra_helpsysinfo` command to verify that a transaction log associated with this Mirror Replication Agent instance exists in the primary database:

```
ra_helpsysinfo
```

If a transaction log does not exist for this Mirror Replication Agent instance, the `ra_helpsysinfo` command returns no information about transaction log objects. If no transaction log exists, you do not need to complete this procedure.

Note The `ra_helpsysinfo` command looks for transaction log components based on the current value of the `pdb_xlog_prefix` configuration parameter. If the value of the `pdb_xlog_prefix` parameter changed after a transaction log was created for a Mirror Replication Agent instance, the `ra_helpsysinfo` command will not find the previously created transaction log.

If a transaction log exists for this Mirror Replication Agent instance, the `ra_helpsysinfo` command returns a list of the names of the transaction log database objects. Continue this procedure to remove the transaction log from the primary database.

- 3 Use the `pdb_setreptable` command to disable replication for all marked tables in the primary database:

```
pdb_setreptable all, disable
```

When you invoke the `pdb_setreptable` command with the `all` and `disable` keywords, Mirror Replication Agent disables replication for all marked tables in the primary database.

- 4 Use the `pdb_setrepproc` command to disable replication for all marked procedures in the primary database:

```
pdb_setrepproc all, disable
```

- 5 Use the `pdb_setreptable` command to unmark all marked tables in the primary database:

```
pdb_setreptable all, unmark
```

When you invoke the `pdb_setreptable` command with the `all` and `unmark` keywords, Mirror Replication Agent removes replication marking from all marked tables in the primary database.

If there are pending transactions for any trigger-based table that you attempt to unmark, `pdb_setreptable` returns an error message. You can force an unmark, regardless of pending transactions or the table's enable status, by following the `unmark` keyword with the `force` keyword:

```
pdb_setreptable all, unmark, force
```

- 6 Use the `pdb_setrepproc` command to unmark all marked procedures in the primary database:

```
pdb_setrepproc all, unmark
```

When you invoke the `pdb_setrepproc` command with the `all` and `unmark` keywords, Mirror Replication Agent removes replication marking from all marked procedures in the primary database.

If there are pending transactions for any trigger-based procedure that you attempt to unmark, `pdb_setrepproc` returns an error message. You can force an unmark, regardless of pending transactions or the procedure's enable status, by following the `unmark` keyword with the `force` keyword:

```
pdb_setrepproc all, unmark, force
```

Note Usually, if any objects in the primary database are marked for replication, you cannot remove the Mirror Replication Agent transaction log.

- 7 Use the `ra_deinit` command to remove the Mirror Replication Agent transaction log:

```
ra_deinit
```

Note When you invoke the `ra_deinit` command, the command returns an error message if no transaction log exists in the primary database.

After you invoke the `ra_deinit` command, Mirror Replication Agent generates a script that, when executed, removes the transaction log base objects from the primary database.

If the log removal script executes successfully, the script is stored in a file named *partdeinit.sql* in the *MA-15_0\inst_name\scripts\xlog\installed* directory.

If the log removal script does not execute successfully, the script is stored in a file named *partdeinit.sql* in the *MA-15_0\inst_name\scripts\xlog* directory.

Forcing transaction log removal

When you invoke the `ra_deinit` command, Mirror Replication Agent creates a script (*partdeinit.sql*) that, when executed successfully, removes all transaction log objects from the primary database.

In the event that the *partdeinit.sql* script fails for some reason, some transaction log components may be removed from the primary database and some components may remain.

Note If errors cause a script execution failure, refer to your primary database error logs and the Mirror Replication Agent system log to evaluate the errors and determine if any corrective action is necessary.

To finish removing transaction log components after a script execution failure, invoke the `ra_deinit` command with the `remove` keyword, followed by the `force` keyword:

```
ra_deinit remove, force
```

When you use the `force` keyword, the removal processing continues—even when errors are encountered.

Truncating the Mirror Replication Agent transaction log

The Mirror Replication Agents for ASE and Oracle support both automatic and manual transaction log truncation.

You can enable or disable automatic log truncation at any time, and you can truncate the Mirror Replication Agent transaction log manually at any time, with automatic log truncation either enabled or disabled.

Note The Mirror Replication Agent for Oracle supports transaction log truncation by controlling archive operations against the Oracle *redo log* and *archive log* files. See the Mirror Replication Agent *Primary Database Guide* for details.

When the Mirror Replication Agent truncates its transaction log, either automatically or on command (manually), the truncation point is determined by the most recent LTM Locator received from the primary Replication Server.

Automatic truncation

You have two options for automatic transaction log truncation:

- Automatic truncation each time the Mirror Replication Agent receives a new LTM Locator value from the primary Replication Server
- Periodic truncation on a time interval you specify

Mirror Replication Agent truncates the transaction log based on the most recent truncation point received from the primary Replication Server. The truncation point is part of the information contained in the LTM Locator.

❖ To enable automatic log truncation

- 1 Log in to the Mirror Replication Agent instance with the administrator login.
- 2 Use the `ra_config` command to enable automatic log truncation and specify the type of automatic truncation:
 - Use the following command to enable automatic log truncation at a specified time interval:

```
ra_config truncation_type, interval
```

- Use the following command to enable automatic log truncation whenever the Mirror Replication Agent receives a new LTM Locator value from the primary Replication Server:

```
ra_config truncation_type, locator_update
```

- 3 If you enabled automatic log truncation based on a time interval, use `ra_config` to specify the time interval for automatic truncation:

```
ra_config truncation_interval, N
```

where *N* is the number of seconds between automatic truncations.

Note The maximum `truncation_interval` value is 720.

See the Mirror Replication Agent *Reference Manual* for more information about the `truncation_interval` and `truncation_type` configuration parameters.

❖ **To disable automatic log truncation**

- 1 Log in to the Mirror Replication Agent instance with the administrator login.
- 2 Use the `ra_config` command to disable automatic log truncation:

```
ra_config truncation_type, command
```

Note If the value of the `truncation_type` parameter is `interval`, and the value of the `truncation_interval` parameter is 0 (zero), automatic log truncation is effectively disabled.

Manual truncation

If automatic log truncation is disabled, you must periodically truncate the Mirror Replication Agent transaction log manually.

❖ **To truncate the Mirror Replication Agent transaction log manually**

- 1 Log in to the Mirror Replication Agent instance with the administrator login.
- 2 Use the following command to truncate the Mirror Replication Agent transaction log:

```
pdb_truncate_xlog
```

The `pdb_truncate_xlog` command is asynchronous; it does not return success or failure, unless an immediate error occurs.

See the Mirror Replication Agent *Reference Manual* for more information about the `pdb_truncate_xlog` command.

Note As an alternative to the Mirror Replication Agent automatic log truncation feature, use a scheduler utility to execute the `pdb_truncate_xlog` command in a script.

Backing up Mirror Replication Agent objects in the primary database

The Mirror Replication Agent does not support automatically backing up and restoring Mirror Replication Agent objects in the primary database.

Sybase recommends that you use the database backup utilities provided by your primary database vendor to periodically back up the Mirror Replication Agent transaction log objects in the primary database.

Managing the Replication Agent System Database

Mirror Replication Agent uses an embedded database for its Replication Agent System Database (RASD).

There are five tasks you can perform to maintain the RASD:

- Updating the RASD
- Updating the log device repository
- Backing up the RASD
- Restoring the RASD
- Truncating the RASD

RASD overview

Each Mirror Replication Agent instance depends on the information in its RASD to recognize database structure or schema objects in the transaction log, and to keep track of mirror log devices.

The Mirror Replication Agent RASD is an important fault-tolerance feature of the Mirror Activator system. It allows the Mirror Replication Agent to recover from failures in its own environment, so that all logged transactions on the mirror log devices can be replicated when the Mirror Replication Agent starts up, even when the primary database is offline.

When you create a Mirror Replication Agent instance, the RASD is created automatically, but it contains no information until you *initialize* the Mirror Replication Agent instance. When you initialize a Mirror Replication Agent instance, it does the following:

Note Before you can start replication with the Mirror Activator system, you must initialize the Mirror Replication Agent instance after the instance is created and its connection configuration parameters are set. You must execute the `ra_init` command to load the RASD. For more information, see Chapter 2, “Setting Up and Configuring Mirror Replication Agent.”

- Queries the primary database to get information about the database structure or schema
- Queries the primary database to get information about the transaction log devices
- Stores information about the database schema and transaction log devices in its RASD

Initializing the Mirror Replication Agent is one of the tasks required to set up the Mirror Activator system, and it has several prerequisites. For more information about these tasks and how to initialize the Mirror Replication Agent, see “Setting up the Mirror Activator system” on page 17.

After the RASD is initially populated, its contents will be synchronized with the primary database automatically during normal replication (without intervention).

If replication does not occur, the contents of the RASD becomes stale (out of sync with the primary database), and you should rebuild them before you use it.

DDL commands

Most of the common data definition language (DDL) commands and system procedures executed in the primary database are recorded in the transaction log, and they are replicated to the standby database. When it processes those DDL transactions for replication, the Mirror Replication Agent updates the RASD automatically.

If a DDL command or system procedure produces a change in the primary database schema and the Mirror Replication Agent cannot recognize that command or procedure and update its RASD automatically, a replication failure will occur if a subsequent transaction changes data in an object that is not recorded in the RASD. In that event, you must re-initialize and quiesce the primary database, and force the Mirror Replication Agent to update its RASD. For more information, see “Updating the RASD” on page 109.

Each time it processes a DDL transaction that affects an existing database object, the Mirror Replication Agent creates a new *version* of the object metadata in its RASD. The version of each object is identified by the LTM Locator value of the DDL transaction that changed it.

Previous versions of objects must be kept in the RASD long enough to allow system recovery. For example, replaying a transaction that involved an object before it was changed by DDL could produce an error (or data inconsistency) with the current version of the object.

Note The Mirror Replication Agent does not support replaying transactions from a restored transaction log.

Object versions and LTM Locator values

The Mirror Replication Agent determines which version of each object to use by comparing the object’s current version string with the current LTM Locator value. If the current LTM Locator value is greater than or equal to the value of the object version, the current object metadata is used. If the current LTM Locator value is less than the value of the object version, a previous version of the object metadata must be used.

Without periodic truncation, the size of the RASD can grow indefinitely, as more and more versions of object metadata are added. For more information, see “Truncating the RASD” on page 116.

Updating the RASD

Note The RASD is usually updated automatically during normal replication activity. The following procedure to force an update of the RASD should only be used with the recommendation of Sybase Technical Support when the RASD is suspected of being corrupt.

After the data in the RASD is created by initializing the Mirror Replication Agent instance, the only way to update the RASD is to *re-initialize* the instance using the `ra_init` command with the `force` keyword.

Note Before you re-initialize the Mirror Replication Agent, the primary database must be quiesced.

❖ **To update the RASD**

1 Log in to the Mirror Replication Agent instance with the administrator login.

2 Use the following command to determine the state of the Mirror Replication Agent instance:

```
ra_status
```

3 If the Mirror Replication Agent is in *Admin* state, skip this step and go to step 4.

If the Mirror Replication Agent is in *Replicating* state:

a Use the following command to suspend replication by the Mirror Replication Agent instance:

```
suspend
```

b Use the following command to verify that the Mirror Replication Agent is in *Admin* state:

```
ra_status
```

4 After you verify that the Mirror Replication Agent is in *Admin* state, use the following command to initialize the primary database:

```
pdb_init
```

Warning! Do *not* use the `move_truncpt` option when you re-initialize a primary database that was previously initialized by the Mirror Replication Agent.

If you do not preserve the existing secondary truncation point in the primary database, you will have to re-materialize the standby database before you can resume replication.

5 Before you re-initialize the RASD, you must quiesce the primary database, or otherwise prevent any DDL operations that can change the database objects or schema.

Log in to the primary data server, using a user login that has appropriate permissions or authority, and then quiesce the primary database (or execute the commands that will prevent any DDL operations that change the database objects or schema).

- 6 Use the following command to re-initialize the Mirror Replication Agent and force it to update its RASD:

```
ra_init force
```

The `ra_init force` command does *not* overwrite any existing log device path in the RASD, if all of the following log device information in the RASD matches that returned by the primary data server:

For ASE:

- Database name
- Device ID
- Device name
- Device path

For Oracle:

- Redo group number
- Redo name
- Redo path

For each log device identified in the RASD, if any item in the preceding list does *not* match the information returned by the primary data server, `ra_init force` overwrites the RASD record for that log device with the information returned by the primary data server.

- 7 After the Mirror Replication Agent is initialized, you must release the quiesce on the primary database to restore normal client access to the database.

Log in to the primary data server, using a user login that has appropriate permissions or authority, and then release the quiesce on the primary database (or execute the commands necessary to restore normal client access to the database).

- 8 Resume replication in the Mirror Replication Agent:

```
resume
```

- 9 Verify that the Mirror Replication Agent is in *Replicating* state:

ra_status

If the Mirror Replication Agent does not return to *Replicating* state, see Chapter 4, “Troubleshooting Mirror Replication Agent,” for more information.

Updating the log device repository

Mirror Replication Agent stores information about primary log devices in its RASD when you initialize the Mirror Replication Agent instance. Log device information in the RASD is referred to as the *log device repository*.

Unlike other information in the RASD, you can update the log device repository at any time using the `ra_updatedevices` command.

Note If any log device is added, dropped, extended, or moved at the primary database, the Mirror Replication Agent log device repository must be updated. Sybase recommends that you coordinate all log device changes at the primary database with updating the Mirror Replication Agent log device repository.

When you update the log device repository, Mirror Replication Agent does the following:

- Queries the primary database for information about all of its log devices.
- Compares the information returned by the primary database with the information recorded in the log device repository.
- Updates the log device repository with the new information returned by the primary database, if:
 - It finds information for existing log devices in the log device repository that does not match the information returned by the primary database, or
 - It finds information about new log devices in the information returned by the primary database.

If the path for a log device at the primary site is different from the path for the corresponding log device at the standby site, you must use `ra_devicepath` to specify the path to the log device recorded in the RASD.

Note The primary database need not be quiesced when you update the Mirror Replication Agent log device repository.

❖ **To update the log device repository**

1 Log in to the Mirror Replication Agent instance with the administrator login.

2 Use the following command to determine the state of the Mirror Replication Agent instance:

```
ra_status
```

3 If the Mirror Replication Agent is in *Admin* state, skip this step and go to step 4.

If the Mirror Replication Agent is in *Replicating* state:

a Suspend replication by the Mirror Replication Agent instance:

```
suspend
```

b Verify that the Mirror Replication Agent is in *Admin* state:

```
ra_status
```

4 If you coordinate log device changes at the primary database with updating the Mirror Replication Agent log device repository, make the log device changes at the primary database after the Mirror Replication Agent is in *Admin* state.

5 After you verify that the Mirror Replication Agent is in *Admin* state, update the log device repository in the RASD:

```
ra_updatedevices
```

6 If you need to specify the path for a log device, use `ra_devicepath`:

```
ra_devicepath device, dev_path
```

where:

- *device* is the device ID (Oracle Group ID).

- *dev_path* is the path that the Mirror Replication Agent must use to connect to the primary database log device at the standby site.

Note You must invoke *ra_devicepath* once for each log device whose path you need to specify.

- 7 Start replication in the Mirror Replication Agent instance:

```
resume
```

You can update the log device repository as often as necessary to accommodate log device changes at the primary database.

Backing up the RASD

Like any database, you should periodically back up the RASD to prevent data loss in the event of a device failure.

Note Sybase recommends that you always back up the RASD before you truncate the RASD.

You can back up the RASD at any time, when the Mirror Replication Agent instance is in any state.

The Mirror Replication Agent places RASD backup files in the directory identified by the *rasd_backup_dir* configuration parameter. For more information about the *rasd_backup_dir* parameter, see the Mirror Replication Agent *Reference Manual*.

❖ To back up the RASD

- 1 Log in to the Mirror Replication Agent instance with the administrator login.
- 2 Back up the RASD:

```
rasd_backup
```

After the backup completes successfully, the Mirror Replication Agent returns a confirmation message.

If the Mirror Replication Agent could not find the directory identified in the `rasd_backup_dir` parameter, or if it could not write the RASD backup files in that directory (for example, because of a permission problem), it returns an error. You must correct the cause of the error before you can successfully back up the RASD.

Restoring the RASD

If the RASD becomes corrupt (for example, because of a device failure), you can restore the database from the most recent backup files.

The Mirror Replication Agent retrieves the RASD backup files from the directory identified by the `rasd_backup_dir` configuration parameter. For more information about the `rasd_backup_dir` parameter, see the Mirror Replication Agent *Reference Manual*.

Note To restore the RASD, the Mirror Replication Agent instance must be in *Admin* state.

❖ To restore the RASD

1 Log in to the Mirror Replication Agent instance with the administrator login.

2 Use the following command to determine the state of the Mirror Replication Agent instance:

```
ra_status
```

3 If the Mirror Replication Agent is in *Admin* state, skip this step and go to step 4.

If the Mirror Replication Agent is in *Replicating* state:

a Use the following command to suspend replication by the Mirror Replication Agent instance:

```
suspend
```

b Use the following command to verify that the Mirror Replication Agent is in *Admin* state:

```
ra_status
```

4 After you verify that the Mirror Replication Agent is in *Admin* state, use the following command to restore the RASD:

```
rasd_restore
```

After the restore operation completes successfully, the Mirror Replication Agent returns a message to confirm that the RASD restore was successful.

If the Mirror Replication Agent cannot find the directory identified in the `rasd_backup_dir` parameter, or if it cannot read the RASD backup files in that directory (for example, because of a permission problem), it returns an error. You must correct the cause of the error to restore the RASD.

- 5 After the RASD is successfully restored from the most recent backup, use the following command to resume replication in the Mirror Replication Agent instance:

```
resume
```

If the Mirror Replication Agent does not return to *Replicating* state, see Chapter 4, “Troubleshooting Mirror Replication Agent,” for more information.

Truncating the RASD

To keep the RASD from growing indefinitely, you can periodically truncate older versions of its primary database object metadata.

Note Back up the RASD using `rasd_backup` *before* you truncate it. For more information, see “Backing up the RASD” on page 114.

The RASD stores definitions for two types of database objects:

- Articles – tables and stored procedures that are marked for replication
- Users – database users who apply transactions in the primary database

Use the `ra_truncatearticles` and `ra_truncateusers` commands to manage the size of the RASD.

Note You can truncate the RASD at any time, when the Mirror Replication Agent instance is in any state.

❖ To truncate older versions of articles in the RASD

- 1 Log in to the Mirror Replication Agent instance with the administrator login.

- 2 Use the following command to truncate articles in the RASD:

```
ra_truncatearticles NNN
```

where *NNN* is an LTM Locator value that identifies the oldest non-current version of any article to be kept.

All non-current versions of all articles that are *less than* the LTM Locator value you specify are truncated from the RASD. If the current (most recent) version of an article is older than the version identified by the LTM Locator value, it is *not* truncated.

❖ **To truncate older versions of users in the RASD**

- 1 Log in to the Mirror Replication Agent instance with the administrator login.
- 2 Use the following command to truncate users in the RASD:

```
ra_truncateusers NNN
```

where *NNN* is an LTM Locator value that identifies the oldest non-current version of any user to be kept.

All non-current versions of all users that are *less than* the LTM Locator value you specify are truncated from the RASD. If the current (most recent) version of a user is older than the version identified by the LTM Locator value, it is *not* truncated.

Identifying replicated transactions and procedures

In a Sybase transaction replication system, the Mirror Replication Agent and Replication Server components both provide features that allow you to identify (or select) the transactions that you want to replicate. You do not need to replicate all transactions, or all data-changing operations, in the primary database.

The ability to select transactions for replication is particularly useful when you need to implement a replication system to support an application that uses some of the tables in a database, but not all of them.

By marking tables, you identify the specific tables in the primary database for which transactions are replicated. Transactions that affect the data in marked tables are referred to as *replicated transactions*.

Note If a transaction affects data in both marked and unmarked tables, only the operations that affect data in marked tables are replicated.

By marking stored procedures, you identify (or select) the specific procedures in the primary database that will be replicated as *applied functions*. When a marked procedure is invoked in the primary database, its invocation is replicated, along with its input parameter values, to the replicate database.

The ability to select procedures for replication is particularly useful when you need to implement a replication system to support an application that uses stored procedures, or when replicating a single procedure invocation is more efficient than replicating numerous, individual data-changing operations that are produced by a single procedure invocation.

Mirror Replication Agent provides the following features to allow you to select replicated transactions and procedures:

- Marking and unmarking tables
- Enabling and disabling replication for marked tables
- Enabling and disabling replication for LOB columns
- Marking and unmarking stored procedures
- Enabling and disabling replication for stored procedures
- Enabling and disabling replication for DDL
- *For Oracle only:* Marking and unmarking sequences

Note By default, Mirror Replication Agent marks and enables DDL and all user tables and their LOB columns for replication when the Mirror Replication Agent is initialized using the `ra_init` command.

If this is not the default behavior desired, you can turn off automatic marking of tables using the `pdb_automark_tables` configuration parameter.

Preparing to mark tables or stored procedures

Before you can mark tables or stored procedures for replication, you must create the Mirror Replication Agent transaction log objects.

See the following for more information:

- “Setting up the Mirror Activator system”
- “Managing the Replication Agent System Database”

Marking and unmarking tables

For ASE only: Primary database initialization (command `pdb_init`) verifies the database and it will be configured with command `sp_reptostandby pdb,'ALL'`. This automatically marks all tables for replication, as well as all DDL commands.

Note For ASE only, individual tables can not be marked or unmarked when the primary database is configured with `sp_reptostandby` (which is the default ASE setting for a Mirror Activator environment).

For Oracle only: The individual tables to be replicated must be marked, either explicitly using the `pdb_setreptable` command, or automatically during `ra_init` processing when configuration parameter `pdb_automark_tables` is set to true.

To replicate transactions that affect the data in a table in the primary database, that table must be marked for replication, and replication must be enabled for the marked table.

Note By default, Mirror Replication Agent creates a replication definition in Replication Server for each table that is explicitly marked for replication. Also, Mirror Replication Agent creates a replication definition for each table created during replication (by reading the DDL command). If this is not the default behavior desired, you can turn off automatic replication definition creation using the `pdb_auto_create_repdefs` configuration parameter.

Marking a table can be separate from enabling replication for that table. If the value of the `pdb_dflt_object_repl` parameter is true, replication is enabled automatically at the time a table is marked. For more information, see “Enabling and disabling replication for marked tables” on page 126.

Note By default, Mirror Replication Agent will mark and enable user tables and their LOB columns for replication when the Mirror Replication Agent is initialized using the `ra_init` command.

If this is not the default behavior desired, you can turn off automatic marking of tables using the `pdb_automark_tables` configuration parameter.

Table marking with
Mirror Replication
Agent

When a table is marked for replication, the Mirror Replication Agent does the following:

- Connects to the RASD
- Records the mark status for the table in the RASD Article for that table.

When a table is marked and enabled, any subsequent operations that affect the data in that table are replicated.

Table unmarking with
Mirror Replication
Agent

When you unmark a table marked for replication, the Mirror Replication Agent does the following:

- Connects to the RASD
- Records the unmark status for the table in the RASD Article for that table

When a table is unmarked, any subsequent operations that affect the data in that table are ignored (not replicated).

Marking a table for replication

Note *For ASE only:* Individual tables can not be marked or unmarked when the primary database is configured with `sp_reptostandby` (which is the default ASE setting for a Mirror Activator environment).

To mark a table for replication use the `pdb_setreptable` command. It returns replication marking status; marks all user tables or a specified table for replication; and enables replication for all marked tables or a specified table. The following is an example of the `pdb_setreptable` command that returns replication marking information for all marked tables in the primary database:

```
pdb_setreptable mark
```

Note By default, Mirror Replication Agent creates a repdef in Replication Server for each table that is explicitly marked for replication. Also, Mirror Replication Agent creates a replication definition for each table created during replication (by reading the DDL command). If this is not the default behavior desired, you can turn off automatic replication definition creation using the `pdb_auto_create_repdefs` configuration parameter.

Use the following procedure to mark tables for replication with Mirror Replication Agent.

❖ **To mark a table in the primary database for replication**

- 1 Log in to the Mirror Replication Agent instance with the administrator login.
- 2 Use the `pdb_setreptable` command to determine if the table is already marked:

```
pdb_setreptable pdb_table
```

where *pdb_table* is the name of the table that you want to mark for replication.

If the `pdb_setreptable` command returns information that the specified table is marked for replication, you do not need to continue this procedure.

If the `pdb_setreptable` command returns information that the specified table is not marked, continue this procedure to mark the table for replication.

- 3 Use the `pdb_setreptable` command to mark the table for replication.

The `pdb_setreptable` command allows you to mark the primary table to be replicated and specify a different table name to use in the replicate database (as specified in a replication definition).

- Use the following command to mark the table for replication when the replicate table (in the replicate database) has the same table name:

```
pdb_setreptable pdb_table, mark
```

where *pdb_table* is the name of the table that you want to mark for replication.

- Use the following command to mark the table for replication when the replicate table (in the replicate database) has a different table name:

```
pdb_setreptable pdb_table, rep_table, mark
```

where:

- *pdb_table* is the name of the table that you want to mark for replication.
- *rep_table* is the name of the replicate table in the replicate database.

Note When the primary table and replicate table have different names, you must use the `with all tables named rep_table` clause when you create the replication definition in the primary Replication Server.

- When marking a table for replication, you have the option to specify that the table owner's name is sent with the table name in the LTL:
 - If the owner mode is set, then the owner name is used when matching the *repdef* in Mirror Replication Agent.
 - If the owner mode is not set, then the owner name is not used by Mirror Replication Agent for *repdef* name matching.

To specify that the table owner's name is sent with the table name in the LTL, use the `owner` keyword after the `mark` keyword, as shown:

```
pdb_setreptable pdb_table, mark, owner
```

where *pdb_table* is the name of the table that you want to mark for replication.

Note The table owner's name returned from the primary database must be the same as the owner name specified in the replication definition for the table.

If the value of the `pdb_dflt_object_repl` parameter is true, the table you marked for replication is ready for replication immediately after the `pdb_setreptable` command returns successfully.

The default value of the `pdb_dflt_object_repl` parameter is true.

If the value of the `pdb_dflt_object_repl` parameter is true, you can skip step 4 in this procedure.

If the value of the `pdb_dflt_object_repl` parameter is false, you must enable replication for the table, as described in step 4.

- 4 Use the `pdb_setreptable` command to enable replication for a marked table:

```
pdb_setreptable pdb_table, enable
```

where *pdb_table* is the name of the marked table.

After replication is enabled for the table, the Mirror Replication Agent can begin replicating transactions that affect data in that table.

Unmarking a table

To unmark a table for replication use the `pdb_setreptable` command. It returns replication marking status; unmarks all user tables or a specified table for replication; and disables replication for all marked tables or a specified table. The following is an example of the `pdb_setreptable` command that forces unmarking for all marked tables in the primary database:

```
pdb_setreptable all, unmark, force
```

Use the following procedure to unmark tables for replication with Mirror Replication Agent.

❖ To unmark a table in the primary database

- 1 Log in to the Mirror Replication Agent instance with the administrator login.
- 2 Use the `pdb_setreptable` command to confirm that the table is marked in the primary database:

```
pdb_setreptable pdb_table
```

where *pdb_table* is the name of the table in the primary database that you want to unmark.

If the `pdb_setreptable` command returns information that the specified table is marked, continue this procedure to unmark the table.

If the `pdb_setreptable` command does not return information that the specified table is marked, you need not continue this procedure.

- 3 Use the `pdb_setreptable` command to disable replication from the table:

```
pdb_setreptable pdb_table, disable
```

where *pdb_table* is the name of the table in the primary database that you want to disable.

- 4 Use the `pdb_setreptable` command to remove the replication marking from the table:

```
pdb_setreptable pdb_table, unmark
```

where *pdb_table* is the name of the table in the primary database that you want to unmark.

If you need to force the unmark, you can use the following command:

```
pdb_setreptable pdb_table, unmark, force
```

- 5 Use the `pdb_setreptable` command to confirm that the table is no longer marked for replication:

```
pdb_setreptable pdb_table
```

where *pdb_table* is the name of the table in the primary database that you unmarked.

Note You can unmark all marked objects in the primary database by invoking the `pdb_setreptable` command with the `all` keyword.

Enabling and disabling replication for DDL

If you need to temporarily suspend replication of DDL, you can use the `pdb_setrepddl` command to disable replication of DDL. When you are ready to resume replication of DDL, you can use the `pdb_setrepddl` command to enable replication.

Note DDL replication is enabled, by default.

When you set the value of `pdb_setrepddl` to `enable`, all DDL in your primary database is replicated.

Note To replicate DDL, Replication Server must have a database-level replication definition with `replicate DDL` set in the definition. For details on creating a database-level replication definition, see the *Mirror Replication Agent Reference Manual*.

Enabling replication for DDL

- ❖ **To enable replication for DDL in the primary database**
 - 1 Log in to the Mirror Replication Agent administration port.

- 2 Use the `pdb_setrepddl` command without an argument to determine if replication is already enabled for DDL in the primary database:

```
pdb_setrepddl
```

If the `pdb_setrepddl` command returns information that replication is enabled, you do not need to continue this procedure.

If the `pdb_setrepddl` command returns information that replication is not enabled for DDL, continue this procedure to enable replication for DDL.

- 3 Use the `pdb_setrepddl` command to enable replication for DDL:

```
pdb_setrepddl enable
```

After replication is enabled for the DDL, you can resume replicating your primary database.

Disabling replication for DDL

❖ To disable replication for DDL in the primary database

- 1 Log in to the Mirror Replication Agent administration port.
- 2 Use the `pdb_setrepddl` command without an argument to determine if replication is already disabled for DDL in the primary database:

```
pdb_setrepddl
```

If the `pdb_setrepddl` command returns information that replication is disabled, you do not need to continue this procedure.

If the `pdb_setrepddl` command returns information that replication is enabled for DDL, continue this procedure to disable replication for DDL.

- 3 Use the `pdb_setrepddl` command to disable replication for DDL:

```
pdb_setrepddl disable
```

After replication is disabled for the DDL, you can resume replicating your primary database.

See the Mirror Replication Agent *Primary Database Guide* for enabling DDL replication details specific to your primary database.

Enabling and disabling replication for marked tables

Note The process for enabling and disabling replication for marked tables behaves the same for both ASE and Oracle.

If you need to temporarily stop replication for a marked table (for example, when maintenance operations are performed in the primary database), you can disable replication for a marked table without affecting replication for other tables in the primary database. Then, when you are ready to resume replication from that table, you can enable replication for that table without affecting other tables in the database.

To replicate transactions that affect the data in a table, that table must be marked for replication, and replication must be enabled for the marked table. For more information, see “Marking and unmarking tables” on page 119.

Mirror Replication Agent has *articles* in the RASD. An article is an object that has a one-to-one relationship to the tables and has a marked indicator.

When replication is disabled for a marked object, the marking infrastructure remains in place, but no transactions for that object are sent to Replication Server.

Enabling replication for marked tables

Use the following procedure to enable replication for marked tables.

❖ **To enable replication for a marked table**

- 1 Log in to the Mirror Replication Agent instance with the administrator login.
- 2 Use the `pdb_setreptable` command to verify that replication is disabled for the table:

```
    pdb_setreptable pdb_table
```

where *pdb_table* is the name of the marked table you want to enable replication for.

If the `pdb_setreptable` command returns information that the table is marked and has replication disabled, continue this procedure to enable replication for the table.

Note A table must be marked for replication before replication can be enabled or disabled for the table.

- 3 Use the `pdb_setreptable` command to enable replication for the table:

```
pdb_setreptable pdb_table, enable
```

where *pdb_table* is the name of the marked table in the primary database for which you want to enable replication.

After replication is enabled for the table, any transaction that affects the data in that table will be captured for replication.

- 4 You can use the `pdb_setreptable` command again to verify that replication is now enabled for the table:

```
pdb_setreptable pdb_table
```

where *pdb_table* is the name of the marked table for which you want to verify that replication is enabled.

Disabling replication for marked tables

Use the following procedure to disable replication for marked tables.

❖ To disable replication for a marked table

- 1 Log in to the Mirror Replication Agent instance with the administrator login.
- 2 Use the `pdb_setreptable` command to verify that replication is enabled for the table:

```
pdb_setreptable pdb_table
```

where *pdb_table* is the name of the marked table for which you want to disable replication.

If the `pdb_setreptable` command returns information that the table is marked and has replication enabled, continue this procedure to disable replication for the table.

Note A table must be marked for replication before replication can be enabled or disabled for the table.

- 3 Use the `pdb_setreptable` command to disable replication for the table:

```
pdb_setreptable pdb_table, disable
```

where *pdb_table* is the name of the marked table in the primary database for which you want to disable replication.

After replication is disabled for the table, transactions that affect the data in that table will not be captured for replication until replication is enabled again.

- 4 You can use the `pdb_setreptable` command again to verify that replication is now disabled for the table:

```
pdb_setreptable pdb_table
```

where *pdb_table* is the name of the marked table for which you want to verify that replication is disabled.

Enabling and disabling replication for LOB columns

In this document, all columns that contain large object (LOB) datatypes are referred to as LOB columns, regardless of the actual datatype name used by the primary database vendor. To replicate transactions that affect a LOB column, replication must be enabled for that column.

You must enable replication for each LOB column you want to replicate, in addition to marking and enabling replication for the table that contains the LOB column.

- If the value of the `pdb_dflt_column_repl` parameter is `true`, replication is enabled automatically for all LOB columns in a table at the time the table is marked.
- If the value of the `pdb_dflt_column_repl` parameter is `false`, replication is not enabled automatically for any LOB columns in a table at the time the table is marked.

For more information on marking a table for replication see “Marking and unmarking tables” on page 119.

Note The default value for `pdb_dflt_column_repl` is true, meaning that all LOB columns will be marked for replication when the table is marked, by default.

When a table is marked for replication and replication is enabled for that table but not for a LOB column in that table, any part of a transaction that affects the LOB column is not replicated. The portion of a transaction that affects all other non-LOB columns is replicated if the table is marked for replication and replication is enabled for the table.

See the Mirror Replication Agent *Primary Database Guide* for more information on LOB handling for Oracle.

Enabling replication for LOB columns

❖ To enable replication for a LOB column in a marked table

- 1 Log in to the Mirror Replication Agent instance with the administrator login.
- 2 Use the `pdb_setrepcol` command to verify that replication is disabled for the LOB column:

```
pdb_setrepcol pdb_table, pdb_col
```

where:

- `pdb_table` is the name of the marked table that contains the LOB column.
- `pdb_col` is the name of the LOB column.

If the `pdb_setrepcol` command returns information that the LOB column has replication disabled, continue this procedure to enable replication for the column.

Note The table that contains the LOB column must be marked for replication before replication can be enabled or disabled for a LOB column.

- 3 Use the `pdb_setrepcol` command to enable replication for the LOB column:

```
pdb_setrepcol pdb_table, pdb_col, enable
```

where:

- *pdb_table* is the name of the marked table that contains the LOB column.
- *pdb_col* is the name of the LOB column for which you want to enable replication.

After replication is enabled for the LOB column (and if replication is enabled for the table that contains the column), any transaction that affects the data in that column will be replicated.

- 4 You can use the `pdb_setrepcol` command again to verify that replication is now enabled for the LOB column:

```
pdb_setrepcol pdb_table, pdb_col
```

where:

- *pdb_table* is the name of the marked table that contains the LOB column.
- *pdb_col* is the name of the LOB column for which you want to verify that replication is enabled.

Disabling replication for LOB columns

❖ To disable replication for a LOB column in a marked table

- 1 Log in to the Mirror Replication Agent instance with the administrator login.
- 2 Use the `pdb_setrepcol` command to verify that replication is enabled for the LOB column:

```
pdb_setrepcol pdb_table, pdb_col
```

where:

- *pdb_table* is the name of the marked table that contains the LOB column.
- *pdb_col* is the name of the LOB column you want to disable replication for.

If the `pdb_setrepcol` command returns information that the LOB column has replication enabled, continue this procedure to disable replication for the column.

Note The table that contains the LOB column must be marked for replication before replication can be enabled or disabled for a LOB column.

- 3 Use the `pdb_setrepcol` command to disable replication for the LOB column:

```
pdb_setrepcol pdb_table, pdb_col, disable
```

where:

- *pdb_table* is the name of the marked table that contains the LOB column.
- *pdb_col* is the name of the LOB column for which you want to disable replication.

After replication is disabled for the LOB column, transactions that affect the data in that column will not be replicated unless replication is enabled for that column again.

- 4 You can use the `pdb_setrepcol` command again to verify that replication is now disabled for the LOB column:

```
pdb_setrepcol pdb_table, pdb_col
```

where:

- *pdb_table* is the name of the marked table that contains the LOB column.
- *pdb_col* is the name of the LOB column for which you want to verify that replication is disabled.

Marking and unmarking stored procedures

Mirror Replication Agent supports Replication Server function replication by replicating the invocation of stored procedures in the primary database.

Note In this document, the terms *function* and *stored procedure* are synonyms.

Mirror Replication Agent can replicate both *applied functions* and *request functions*:

- Applied functions are stored procedures that are executed in the primary database and generate transactions that affect data in the primary database.
- Request functions are stored procedures that are invoked in one database (for example, a replicate database), then executed in another database (for example, a primary database).

Mirror Replication Agent does not distinguish between these two function types, except to supply a specific user and password for use with request functions. If you are using request functions, the configuration parameters `function_username` and `function_password` must be supplied.

For more information about applied and request functions, see the Managing Replicated Functions chapter of the Replication Server *Administration Guide*.

For more information about the `function_username` and `function_password` configuration parameters, see the Mirror Replication Agent *Reference Manual*.

In order to replicate a stored procedure invoked in a primary database, the stored procedure must be marked for replication, and replication must be enabled for that stored procedure. (This is analogous to marking and enabling replication for tables.)

Note Marking a stored procedure for replication is separate from enabling replication for the stored procedure. If the value of the `pdb_dflt_object_repl` parameter is `true`, replication is enabled automatically at the time a stored procedure is marked. For more information, see “Enabling and disabling replication for stored procedures” on page 136.

If a marked stored procedure performs operations that affect a marked table, the operations that affect the marked table are not captured for replication; only the invocation of the marked stored procedure is replicated.

If you need to temporarily suspend replication of a marked stored procedure (for example, when database maintenance operations are performed in the primary database), you can disable replication for the stored procedure. For more information, see “Enabling and disabling replication for stored procedures” on page 136.

For more information on the Replication Server function replication feature, see the Replication Server *Administration Guide*.

Marking a stored procedure for replication

Note By default, Mirror Replication Agent will create a replication definition in Replication Server for each procedure that is explicitly marked for replication. If this is not the default behavior desired, you can turn off automatic replication definition creation using the `pdb_auto_create_repdefs` configuration parameter.

❖ To mark a stored procedure for replication

- 1 Log in to the Mirror Replication Agent instance with the administrator login.
- 2 Use the `pdb_setrepproc` command to determine if the stored procedure is already marked in the primary database:

```
pdb_setrepproc pdb_proc
```

where *pdb_proc* is the name of the stored procedure in the primary database that you want to mark for replication.

- If the `pdb_setrepproc` command returns information that the specified stored procedure is marked, you do not need to continue this procedure
 - If the `pdb_setrepproc` command returns information that the specified stored procedure is not marked, continue this procedure to mark the stored procedure for replication.
- 3 Use the `pdb_setrepproc` command to mark the stored procedure for replication.

The `pdb_setrepproc` command allows you to mark the primary stored procedure to be replicated and specify a different stored procedure name to use in the replicate database (as specified in a function replication definition).

- Use the following command to mark the stored procedure for replication using a function replication definition with the same stored procedure name:

```
pdb_setrepproc pdb_proc, mark
```

where *pdb_proc* is the name of the stored procedure in the primary database that you want to mark for replication.

- Use the following command to mark the stored procedure for replication using a function replication definition with a different stored procedure name:

```
pdb_setrepproc pdb_proc, rep_proc, mark
```

where:

- *pdb_proc* is the name of the stored procedure in the primary database that you want to mark for replication.
- *rep_proc* is the name of the stored procedure in the function replication definition for this stored procedure.

Consider the following:

- If the value of the `pdb_dflt_object_repl` parameter is true, the stored procedure marked for replication with the `pdb_setrepproc` command is ready for replication after you invoke the `pdb_setrepproc` command successfully.
 - If the value of the `pdb_dflt_object_repl` parameter is true (the default value), you can skip step 4 in this procedure
 - If the value of the `pdb_dflt_object_repl` parameter is false, you must enable replication for the stored procedure before replication can take place
- 4 Use the `pdb_setrepproc` command to enable replication for the marked stored procedure:

```
pdb_setrepproc pdb_proc, enable
```

where *pdb_proc* is the name of the marked stored procedure for which you want to enable replication.

After replication is enabled for the stored procedure, you can begin replicating invocations of that stored procedure in the primary database.

Note *For Oracle only:* If you disabled DDL replication during stored procedure marking, remember to re-enable DDL replication. Since marking of a stored procedure modifies that stored procedure, you must first disable DDL replication to prevent the marking modifications from replicating to the standby site. See “Enabling replication for DDL” on page 124.

Unmarking a stored procedure

The following describes how to unmark a stored procedure.

❖ To unmark a stored procedure

- 1 Log in to the Mirror Replication Agent instance with the administrator login.
- 2 Use the `pdb_setrepproc` command to confirm that the stored procedure is marked in the primary database:

```
pdb_setrepproc pdb_proc
```

where *pdb_proc* is the name of the stored procedure that you want to unmark.

- If the `pdb_setrepproc` command returns information that the specified stored procedure is marked, continue this procedure to unmark the stored procedure.
- If the `pdb_setrepproc` command does not return information that the specified stored procedure is marked, you do not need to continue this procedure.

- 3 Use the `pdb_setrepproc` command to disable replication of the stored procedure:

```
pdb_setrepproc pdb_proc, disable
```

where *pdb_proc* is the name of the stored procedure that you want to unmark.

- 4 Use the `pdb_setrepproc` command to remove the replication marking from the stored procedure:

```
pdb_setrepproc pdb_proc, unmark
```

where *pdb_proc* is the name of the stored procedure that you want to unmark.

If you need to force the unmark, you can use the following command:

```
pdb_setrepproc pdb_proc, unmark, force
```

- 5 Use the `pdb_setrepproc` command to confirm that the stored procedure is no longer marked for replication:

```
pdb_setrepproc pdb_proc
```

where *pdb_proc* is the name of the stored procedure in the primary database that you unmarked.

You can unmark all marked stored procedures in the primary database by invoking the `pdb_setrepproc` command with the `all` keyword.

Note *For Oracle only:* If you disabled DDL replication during stored procedure unmarking, remember to re-enable DDL replication. See “Enabling replication for DDL” on page 124.

Enabling and disabling replication for stored procedures

If you need to temporarily suspend replication of a stored procedure, use the `pdb_setrepproc` command to disable replication for the marked stored procedure. When you are ready to resume replication of the marked stored procedure, use the `pdb_setrepproc` command to enable replication.

To replicate invocations of a stored procedure in the primary database, the stored procedure must be marked for replication, and replication must be enabled for that stored procedure; no procedures are marked by default for replication.

Marking a stored procedure for replication is separate from enabling replication for the stored procedure. For more information, see “Marking and unmarking stored procedures” on page 131.

Enabling replication for stored procedures

❖ To enable replication for a marked stored procedure

- 1 Log in to the Mirror Replication Agent instance with the administrator login.
- 2 Use the `pdb_setrepproc` command to verify that replication is disabled for the stored procedure:

```
pdb_setrepproc pdb_proc
```

where *pdb_proc* is the name of the marked stored procedure you want to enable replication for.

If the `pdb_setrepproc` command returns information that the stored procedure is marked and has replication disabled, continue this procedure to enable replication for the stored procedure.

Note A stored procedure must be marked for replication before replication can be enabled or disabled for the stored procedure.

- 3 Use the `pdb_setrepproc` command to enable replication for the stored procedure:

```
pdb_setrepproc pdb_proc, enable
```

where `pdb_proc` is the name of the marked stored procedure for which you want to enable replication.

After replication is enabled for the stored procedure, any invocation of that stored procedure will be replicated.

- 4 You can use the `pdb_setrepproc` command again to verify that replication is now enabled for the stored procedure:

```
pdb_setrepproc pdb_proc
```

where `pdb_proc` is the name of the marked stored procedure for which you want to verify that replication is enabled.

Disabling replication for stored procedures

❖ To disable replication for a marked stored procedure

- 1 Log in to the Mirror Replication Agent instance with the administrator login.
- 2 Use the `pdb_setrepproc` command to verify that replication is enabled for the stored procedure:

```
pdb_setrepproc pdb_proc
```

where `pdb_proc` is the name of the marked stored procedure you want to disable replication for.

If the `pdb_setrepproc` command returns information that the stored procedure is marked and has replication enabled, continue this procedure to disable replication for the stored procedure.

Note A stored procedure must be marked for replication *before* replication can be enabled or disabled for that stored procedure.

- 3 Use the `pdb_setrepproc` command to disable replication for the stored procedure:

```
pdb_setrepproc pdb_proc, disable
```

where *pdb_proc* is the name of the marked stored procedure for which you want to disable replication.

After replication is disabled for the stored procedure, any invocation of that stored procedure will not be captured for replication until replication is enabled again.

- 4 You can use the `pdb_setrepproc` command again to verify that replication is now disabled for the stored procedure:

```
pdb_setrepproc pdb_proc
```

where *pdb_proc* is the name of the marked stored procedure for which you want to verify that replication is disabled.

Marking and unmarking sequences (for Oracle only)

Mirror Replication Agent supports replication of sequences in the primary database. In order to replicate a sequence invoked in a primary database, the sequence must be marked for replication and replication must be all for that sequence. (This is analogous to marking and enabling replication for tables.)

Note Marking a sequence for replication is separate from enabling replication for the sequence. If the value of the `pdb_dflt_object_repl` parameter is true, replication is enabled automatically at the time a sequence is marked. For more information, see “Enabling and disabling replication for sequences (for Oracle only)” on page 142.

Oracle does not log information every time a sequence is incremented. Sequence replication occurs when the Mirror Replication Agent captures the system table updates that occur when the sequence's cache is refreshed. Therefore, the sequence value replicated when a sequence is marked for replication is the “next” sequence value to be used when the current cache expires. The result is that not every individual increment of a sequence is replicated, but the standby site will always have a value greater than the primary site's currently available cached values.

If you need to temporarily suspend replication of a marked sequence you can disable replication for the sequence. For more information see “Marking and unmarking sequences (for Oracle only)” on page 138.

Marking a sequence for replication

❖ To mark a sequence for replication

- 1 Log in to the Mirror Replication Agent instance with the administrator login.
- 2 Use the `pdb_setrepseq` command to determine if the sequence is already marked in the primary database:

```
pdb_setrepseq pdb_seq
```

where `pdb_seq` is the name of the sequence in the primary database that you want to mark for replication.

- If the `pdb_setrepseq` command returns information that the specified sequence is marked, you do not need to continue this procedure.
- If the `pdb_setrepseq` command returns information that the specified sequence is not marked, continue this procedure to mark the sequence for replication.

❖ To mark a stored procedure for replication

- 1 Log in to the Mirror Replication Agent instance with the administrator login.
- 2 Use the `pdb_setrepproc` command to determine if the stored procedure is already marked in the primary database:

```
pdb_setrepproc pdb_proc
```

where `pdb_proc` is the name of the stored procedure in the primary database that you want to mark for replication.

Consider the following:

- If the `pdb_setrepproc` command returns information that the specified stored procedure is marked, you do not need to continue this procedure.
 - If the `pdb_setrepproc` command returns information that the specified stored procedure is not marked, continue this procedure to mark the stored procedure for replication.
- 3 Use the `pdb_setrepseq` command to mark the sequence for replication.

The `pdb_setrepseq` command allows you to mark the primary stored procedure to be replicated and specify a different sequence name to use in the replicate database.

- Use the following command to mark the sequence for replication when the sequence name you wish to increment at the standby site has a different name:

```
pdb_setrepseq pdb_seq, mark
```

where *pdb_seq* is the name of the sequence in the primary database that you want to mark for replication.

Note Replicating a sequence with a different name that is provided is consistent with other marking commands but is not a typical configuration.

- Use the following command to mark the sequence for replication using a different sequence name:

```
pdb_setrepseq pdb_seq, rep_seq, mark
```

where:

- *pdb_seq* is the name of the sequence in the primary database that you want to mark for replication.
- *rep_seq* is the name of the sequence in the standby database that you wish to increment.

Note Replicating sequence values to a sequence with a different name at the standby site assumes that the standby site's sequence has the same attributes and starting value as the primary site's sequence.

Consider the following:

- If the value of the `pdb_dflt_object_repl` parameter is true, the sequence marked for replication with the `pdb_setrepseq` command is ready for replication after you invoke the `pdb_setrepseq` command successfully.
- If the value of the `pdb_dflt_object_repl` parameter is true (the default value), you can skip step 4 in this procedure.
- If the value of the `pdb_dflt_object_repl` parameter is false, you must enable replication for the sequence before replication can take place.

- 4 Use the `pdb_setrepseq` command to enable replication for the marked sequence:

```
pdb_setrepseq pdb_seq, enable
```

where *pdb_seq* is the name of the marked sequence for which you want to enable replication.

After replication is enabled for the sequence, you can begin replicating invocations of that sequence in the primary database.

Unmarking a sequence

❖ To unmark a sequence

- 1 Log in to the Mirror Replication Agent instance with the administrator login.
- 2 Use the `pdb_setrepseq` command to confirm that the sequence is marked in the primary database:

```
pdb_setrepseq pdb_seq
```

where *pdb_seq* is the name of the sequence that you want to unmark.

Consider the following:

- If the `pdb_setrepseq` command returns information that the specified sequence is marked, continue this procedure to unmark the sequence.
- If the `pdb_setrepseq` command does not return information that the specified sequence is marked, you do not need to continue this procedure.

- 3 Use the `pdb_setrepseq` command to disable replication of the sequence:

```
pdb_setrepseq pdb_seq, disable
```

where *pdb_proc* is the name of the sequence that you want to unmark.

- 4 Use the `pdb_setrepseq` command to remove the replication marking from the sequence:

```
pdb_setrepseq pdb_seq, unmark
```

where *pdb_seq* is the name of the sequence that you want to unmark.

If you need to force the unmark, you can use the following command:

```
pdb_setrepseq pdb_seq, unmark, force
```

- 5 Use the `pdb_setrepseq` command to confirm that the sequence is no longer marked for replication:

```
    pdb_setrepseq pdb_seq
```

where *pdb_seq* is the name of the sequence in the primary database that you unmarked.

Enabling and disabling replication for sequences (for Oracle only)

If you need to temporarily suspend replication of a sequence, you can use the `pdb_setrepseq` command to disable replication for the marked sequence. When you are ready to resume replication of the marked sequence, you can use the `pdb_setrepseq` command to enable replication.

Note No sequences are marked by default for replication.

To replicate updates of a sequence in the primary database, the sequence must be marked for replication and replication must be enabled for that sequence.

Marking a sequence for replication is separate from enabling replication for the sequence. For more information, see “Marking a sequence for replication” on page 139.

Enabling replication for sequences

❖ To enable replication for a marked sequence

- 1 Log in to the Mirror Replication Agent instance with the administrator login.
- 2 Use the `pdb_setrepseq` command to verify that replication is disabled for the sequence:

```
    pdb_setrepseq pdb_seq
```

where *pdb_seq* is the name of the marked sequence you want to enable replication for.

If the `pdb_setrepseq` command returns information that the sequence is marked and has replication disabled, continue this procedure to enable replication for the sequence.

Note A sequence must be marked for replication before replication can be enabled or disabled for the sequence.

- 3 Use the `pdb_setrepseq` command to enable replication for the sequence:

```
pdb_setrepseq pdb_seq, enable
```

where *pdb_seq* is the name of the marked sequence for which you want to enable replication.

After replication is enabled for the sequence, any invocation of that sequence will be replicated.

- 4 You can use the `pdb_setrepseq` command again to verify that replication is now enabled for the sequence:

```
pdb_setrepseq pdb_seq
```

where *pdb_seq* is the name of the marked sequence for which you want to verify that replication is enabled.

Disabling replication for marked sequence

❖ To disable replication for a marked sequence

- 1 Log in to the Mirror Replication Agent instance with the administrator login.
- 2 Use the `pdb_setrepseq` command to verify that replication is enabled for the sequence:

```
pdb_setrepseq pdb_seq
```

where *pdb_seq* is the name of the marked sequence you want to disable replication for.

If the `pdb_setrepseq` command returns information that the sequence is marked and has replication enabled, continue this procedure to disable replication for the sequence.

Note A sequence must be marked for replication before replication can be enabled or disabled for that sequence.

- 3 Use the `pdb_setrepseq` command to disable replication for the sequence:

```
pdb_setrepseq pdb_seq, disable
```

where *pdb_seq* is the name of the marked sequence for which you want to disable replication.

After replication is disabled for the sequence, any invocation of that sequence will not be captured for replication until replication is enabled again.

- 4 You can use the `pdb_setrepseq` command again to verify that replication is now disabled for the sequence:

```
pdb_setrepseq pdb_seq
```

where *pdb_seq* is the name of the marked sequence for which you want to verify that replication is disabled.

Configuring and tuning the Mirror Replication Agent

The performance of Mirror Replication Agent can be tuned or optimized by adjusting some of the Mirror Replication Agent configuration parameters.

You can set or change a Mirror Replication Agent configuration parameter with the `ra_config` command.

Because the Mirror Replication Agent overwrites its entire configuration file whenever `ra_config` or `ra_set_login` is invoked, Sybase recommends that you *do not* edit the configuration file. Also, each Mirror Replication Agent instance reads its configuration file only at start-up. You must use the `ra_config` command if you want a new configuration parameter value to take effect before the instance is shut down and restarted.

Note Some configuration parameter changes are recorded in the configuration file when you invoke `ra_config`, but they do not take effect until the Mirror Replication Agent instance is shut down and restarted.

All Mirror Replication Agent configuration parameters can be changed when the Mirror Replication Agent instance is in *Admin* state. Some configuration parameters *cannot* be changed when the instance is in *Replicating* state.

Table 3-1 lists all Mirror Replication Agent configuration parameters.

Table 3-1: Mirror Replication Agent configuration parameters

Parameter name	Target	Description	Default
admin_port	All	Port number on which Mirror Replication Agent listens for incoming user connections.	10000
column_compression	All	Use minimal column information.	true
compress_ltl_syntax	All	Use abbreviated LTL syntax.	true
connect_to_rs	All	Enable/disable connection from LTI to Replication Server.	true
ddl_password	Oracle	Password for user ID passed in LTL with replicated DDL invocations.	<not_configured>
ddl_username	Oracle	User ID passed in LTL with replicated DDL invocations.	<not_configured>
dump_batch_timeout	All	Time to send incomplete buffer to Replication Server.	5
filter_maint_userid	All	Log Reader filters operations with maintenance user ID.	true
function_password	Oracle	Password for user ID passed in LTL with replicated stored procedure invocations.	"" (empty string)
function_username	Oracle	User ID passed in LTL with replicated stored procedure invocations.	sa
log_backup_files	All	Determines the number of log backup files kept in the log directory.	3
log_directory	All	Directory where Mirror Replication Agent system log file is located.	Current directory on the Mirror Replication Agent host machine from which the Mirror Replication Agent instance was started.
log_trace_verbose	All	Switch on/off verbose mode in trace log file.	false

Parameter name	Target	Description	Default
log_wrap	All	Number of 1KB byte blocks written to log file before wrapping.	1000
lti_batch_mode	All	Specifies whether to batch the LTL commands sent to Replication Server.	true
lti_max_buffer_size	All	Maximum number of change sets stored in the LTI input buffer.	5000
lti_update_trunc_point	All	Number of LTL commands sent before LTI requests new LTM Locator.	1000
ltl_batch_size	All	Size of the LTL batch buffer.	40000
ltl_big_endian_unitext	All	Specifies whether "unitext" data should be converted from little endian to big endian before sending LTL to Replication Server.	true
ltl_character_case	All	Case of database object names sent to Replication Server.	asis
ltl_origin_time_required	All	Specifies whether to send origin_time command tag in LTL.	false
ltm_admin_pw	All	Password for Mirror Replication Agent administrative port.	"" (empty string)
ltm_admin_user	All	User ID for Mirror Replication Agent administrative port.	sa
max_ops_per_scan	All	Maximum number of operations Log Reader will read in a single log scan.	1000
pdb_archive_path	Oracle	Identifies the directory path where the Replication Agent expects to find archived Oracle redo log files.	none

Parameter name	Target	Description	Default
<code>pdb_archive_remove</code>	Oracle	Enables or disables the removal of archived Oracle <i>redo log</i> files from the path specified by <code>pdb_archive_path</code> .	false
<code>pdb_automark_tables</code>	All	Automatic marking of user tables when the Replication Agent is initialized.	true
<code>pdb_auto_create_repdefs</code>	All	Automatic creation of Replication Definitions when tables or procs are marked.	true
<code>pdb_auto_run_scripts</code>	Oracle	Automatic execution of SQL scripts used to create/remove transaction log objects and mark/unmark primary database objects.	true
<code>pdb_convert_datetime</code>	Oracle	Converts native date/time formats to Sybase <code>datetime</code> format.	false
<code>pdb_dflt_column_repl</code>	All	Enables replication for LOB columns by default when table is marked.	true
<code>pdb_dflt_object_repl</code>	All	Enables replication by default when object is marked.	true
<code>pdb_include_archives</code>	Oracle	Enables or disables the use of Oracle archive log files.	true
<code>pdb_support_large_identifier</code>	All	To support replication of large identifiers up to 255 characters in length.	true
<code>pdb_timezone_file</code>	Oracle	Specifies the file to read at initialization to obtain Oracle time zone information.	none
<code>pdb_xlog_device</code>	Oracle	Name of the primary database device.	NULL

Parameter name	Target	Description	Default
pdb_xlog_prefix	Oracle	Character string prefix used to identify transaction log objects.	ra_
pdb_xlog_prefix_chars	Oracle	Non-alphabetic characters allowed in <code>pdb_xlog_prefix</code> .	_#\$
pds_connection_type	All	Type of connection to primary data server.	For Oracle: ORAJDBC
pds_database_name	All	Name of database replicated from primary data server.	<not_configured>
pds_datasource_name	All	Data source name of database replicated from primary data server.	<not_configured>
pds_host_name	All	Name of primary data server host machine.	<not_configured>
pds_password	All	Password for user ID Mirror Replication Agent uses to access primary data server.	"" (empty string)
pds_port_number	All	Port number for primary data server.	1111
pds_retry_count	All	Number of times to retry connection to primary data server.	5
pds_retry_timeout	All	Number of seconds to wait between connection retry attempts.	10
pds_server_name	All	Server name of primary data server.	<not_configured>
pds_username	All	User ID that Mirror Replication Agent uses to access primary data server.	<not_configured>
ra_retry_count	All	Number of times LTM attempts to get back to <i>Replicating</i> state after a failure.	2
ra_retry_timeout	All	Number of seconds to wait between LTM attempts to get back to <i>Replicating</i> state.	10

Parameter name	Target	Description	Default
rasd_backup_dir	All	The directory path for Replication Agent System Database (RASD) backup files.	<not_configured>
rasd_database	All	The directory path for the Replication Agent System Database (RASD) database file.	<not_configured>
rasd__mirror_tran_log	All	Enables or disables Replication Agent System Database (RASD) transaction log mirroring.	false
rasd_trace_log_dir	All	The directory path for the Replication Agent System Database (RASD) trace log file.	<not_configured>
rasd_tran_log	All	The directory path for the Replication Agent System Database (RASD) transaction log file.	<not_configured>
rasd__tran_log_mirror	All	The directory path for the Replication Agent System Database (RASD) transaction log file mirror.	path to the RASD transaction log file
rs_charset	All	Character set used to communicate with Replication Server.	"" (empty string)
rs_host_name	All	Name of primary Replication Server host machine.	<not_configured>
rs_packet_size	All	Network I/O packet size sent to Replication Server.	2048
rs_password	All	Password for user ID Mirror Replication Agent uses to access Replication Server.	"" (empty string)
rs_port_number	All	Port number for primary Replication Server.	1111
rs_retry_count	All	Number of times to retry connection to primary Replication Server.	5

Parameter name	Target	Description	Default
rs_retry_timeout	All	Number of seconds to wait between connection retry attempts.	10
rs_source_db	All	Name of primary database identified to Replication Server.	<not_configured>
rs_source_ds	All	Name of primary data server identified to Replication Server.	<not_configured>
rs_username	All	User ID that Mirror Replication Agent uses to access primary Replication Server.	<not_configured>
rssd_charset	All	Character set used to communicate with RSSD.	"" (empty string)
rssd_database_name	All	Name of RSSD database.	<not_configured>
rssd_host_name	All	Name of RSSD host machine.	<not_configured>
rssd_password	All	Password for user ID Mirror Replication Agent uses to access RSSD.	"" (empty string)
rssd_port_number	All	Port number for RSSD.	1111
rssd_username	All	User ID that Mirror Replication Agent uses to access RSSD.	<not_configured>
scan_sleep_increment	All	Number of seconds to increase Log Reader wait before next scan after finding no operations to replicate.	5
scan_sleep_max	All	Maximum number of seconds for Log Reader to wait before next scan after finding no operations to replicate.	60
skip_ltl_errors	All	LTI ignores error messages returned by Replication Server.	false
structured_tokens	All	LTI uses structured tokens when generating LTL output.	true

Parameter name	Target	Description	Default
truncation_interval	Oracle	Number of minutes to wait between automatic log truncations.	0
truncation_type	Oracle	Method(s) of log truncation allowed.	locator_update
use_rssd	All	Switches on/off access to RSSD for replication definitions.	true

For more information about the `ra_config` command and Mirror Replication Agent configuration parameters, see the Mirror Replication Agent *Reference Manual*.

Configuring Mirror Replication Agent

To set or change a Mirror Replication Agent configuration parameter, use the `ra_config` command.

Because the Mirror Replication Agent overwrites its entire configuration file whenever `ra_config` or `ra_set_login` is invoked, Sybase recommends that you *do not* edit the configuration file. Also, Mirror Replication Agent reads the configuration file only at start-up. You must use the `ra_config` command if you want a new configuration parameter value to take effect before the Mirror Replication Agent is shut down and restarted.

Note Some configuration parameter changes are recorded in the configuration file when you invoke `ra_config`, but do not take effect until the Mirror Replication Agent is shut down and restarted.

Customizing tuning

Generally, Mirror Replication Agent's default configuration values provide optimal performance. However, there may be certain situations where the configuration should be changed to suit or optimize your particular environment.

Adjusting the size and volume of the Mirror Replication Agent system logs

By default, the system logs produced by the Mirror Replication Agent are a pre-set size. They roll over occasionally to prevent continual disk consumption.

You can adjust the size of a log and adjust the number of backup files:

- By increasing these sizes, you can save log data for a longer period of time.
- By decreasing them, you can increase the unused space in your environment.

❖ To adjust the size and volume of log files

- 1 Log in to the running Mirror Replication Agent instance using the administrator login.
- 2 Verify that the Mirror Replication Agent instance is in *Admin* state:

```
ra_status
```

- 3 Use the `ra_config` command to set the values of the following Mirror Replication Agent configuration parameters for the primary database. Increase the following values if you want to increase the size and number of backup files. Decrease the following values if you want to make more space available in your environment:

```
ra_config log_backup_files, n
```

```
ra_config log_wrap, m
```

Preventing continual spinning at the end of a log scan

Mirror Replication Agent uses the configuration parameters `scan_sleep_increment` and `scan_sleep_max` to “pause” scanning when the end of the log is reached. This prevents Mirror Replication Agent from continually “spinning” on the end of the log. The downside is that Mirror Replication Agent may pause up to 60 seconds (by default) before a new transaction appears, because it was sleeping. When you need the maximum possible latency for a transaction to be less than the 60-second default, you can reduce the scan parameters. This results in additional CPU usage when the end of the log is reached.

Conversely, if CPU maximization is a greater concern than latency, you can increase these parameters to allow Mirror Replication Agent to use less CPU on an inactive log, at the cost of having the latency of the “next” transaction increased.

Note These parameters have effect *only* when the end of the log has been reached and there is no additional activity to be replicated. By default, Mirror Replication Agent immediately re-scans (without pause) when the end of the log has not been reached.

Troubleshooting Mirror Replication Agent

This chapter describes basic troubleshooting procedures for Mirror Replication Agent and the Mirror Activator system.

Topic	Page
Diagnosing command errors and replication errors	155
Troubleshooting specific command errors	156
Examining the Mirror Replication Agent if a failure occurs	156
Checking the Replication Server	164

Diagnosing command errors and replication errors

Problems that prevent replication from starting do not always result in an error message. For example, a Mirror Activator component may not recognize a configuration problem that prevents replication from starting.

In a functioning Mirror Activator system—one that has previously replicated transactions successfully—most system problems result in an error message from one or more of the system's components. However, some problems that interrupt replication might not be interpreted as errors by the system's components. In that case, replication fails, but no error message is returned.

Use the diagnostic and troubleshooting tips in the following sections to identify and correct the cause of a Mirror Activator system problem:

- Troubleshooting specific command errors
- Examining the Mirror Replication Agent if a failure occurs
- Checking the Replication Server

Troubleshooting specific command errors

This section describes troubleshooting for specific errors you may encounter in a Mirror Replication Agent. These error messages can be returned from a command or appear in the log file.

Connection refused

Error message	<pre>Could not connect to <jdbc:sybase:Tds:localhost:5001/emb>: JZ006: Caught IOException: java.net.ConnectException: Connection refused: connectJZ006:</pre>
Explanation	The Mirror Replication Agent attempted to connect to a Sybase server on a host called <i>localhost</i> and port 5001. The error indicates that no server was found.
Action	<p>This is usually a configuration error: Either the server that Mirror Replication Agent is attempting to connect to is not running, or the host and port information configured in Mirror Replication Agent is incorrect.</p> <ul style="list-style-type: none">• Verify that your server is running.• Verify that your Mirror Replication Agent is configured with the correct host and port information. See “Setting up the connection configuration parameters” on page 76 for more information.• Test your connection after you have verified them. For more information, see “Testing network connectivity” on page 80.

Examining the Mirror Replication Agent if a failure occurs

When no transactions appear to be replicated to the replicate database, and you receive specific error messages, see “Troubleshooting specific command errors” on page 156.

When no errors are returned by any Mirror Activator system components:

- Verify primary database objects marked for replication
- Check the Mirror Replication Agent status
- Examine the Mirror Replication Agent logs

- Use the `ra_statistics` command to troubleshoot

Verify primary database objects marked for replication

In a Sybase transaction replication system, both the Mirror Replication Agent and Replication Server components provide features that allow you to select the objects that you want to replicate. You do not need to replicate all objects or all data-changing operations in the primary database.

If a primary database object (such as a table or stored procedure) is not replicating, verify the object that you intended to replicate is marked.

❖ To verify that a primary database object is marked for replication

- 1 Log in to the Mirror Replication Agent instance with the administrator login.
- 2 Use the appropriate command to determine if the object is already marked:

- For a table:

```
pdb_setreptable pdb_table
```

where *pdb_table* is the name of the table that you want to verify is marked for replication.

- For a LOB column:

```
pdb_setrepcol pdb_table, pdb_col
```

where:

- *pdb_table* is the name of the marked table that contains the LOB column.
- *pdb_col* is the name of the LOB column.
- For a stored procedure:

```
pdb_setrepproc pdb_proc
```

where *pdb_proc* is the name of the stored procedure in the primary database that you want to verify is marked for replication.

- For DDL:

```
pdb_setrepddl pdb_ddl
```

where *pdb_ddl* is the name of the DDL in the primary database.

It returns the current DDL replication status for the primary database. Verify that DDL replication status is enabled to replication DDL commands.

After you verify that the primary database objects are marked, see the following table:

If...	Then...
The primary database object is not marked.	Mark the object: <ul style="list-style-type: none"> • Table – see “Marking a table for replication” on page 120. • LOB column – see “Enabling replication for LOB columns” on page 129. • Stored procedure – see “Marking and unmarking stored procedures” on page 131. • DDL – see “Enabling and disabling replication for DDL” on page 124. • Sequence - see “Marking and unmarking sequences (for Oracle only)” on page 138.
The primary database object is marked.	See “Check the Mirror Replication Agent status” on page 158.

Check the Mirror Replication Agent status

The status of the Mirror Replication Agent instance indicates whether it is in *Replicating* state or in *Admin* state.

No replication takes place when the Mirror Replication Agent instance is in *Admin* state. For more information, see “Understanding Mirror Replication Agent states” on page 90.

❖ To check the current Mirror Replication Agent status

- 1 Log in to the Mirror Replication Agent instance with the administrator login.
- 2 Use the following command to check the current status of the Mirror Replication Agent:

```
ra_status
```

This command returns the current state of the Mirror Replication Agent instance, as shown in the following example:

```

State  Action
-----
ADMIN  Waiting for operator command
(1 row affected)
    
```

For more information about the `ra_status` command, see the Mirror Activator Mirror Replication Agent *Reference Manual*.

When the Mirror Replication Agent instance is in one of the following states, take the suggested actions.

If...	Then...
The Mirror Replication Agent instance is in <i>Replicating (Waiting at end of log)</i> state.	Examine the statistics output to check the progress of the replication process. See “Use the <code>ra_statistics</code> command to troubleshoot” on page 161 for more information.
The Mirror Replication Agent instance is <i>Replicating</i> state. Note When the Mirror Replication Agent instance is in the <i>Replicating</i> state, all data may <i>not</i> have yet been replicated. You can only be sure that the Mirror Replication Agent instance is finished replicating when the state is <i>Replicating (Waiting at end of log)</i> .	The instance is operating normally, but it has not reached the end of the transaction log. Wait until Mirror Replication Agent instance is in <i>Replicating (Waiting at end of log)</i> state. Then repeat the procedure on page 158.
The Mirror Replication Agent instance is in <i>Admin</i> state.	Start replication and put the Mirror Replication Agent instance in <i>Replicating</i> state by executing the Mirror Replication Agent <code>resume</code> command. See “Starting replication in the Mirror Replication Agent” on page 95 for more information. If the Mirror Replication Agent instance returns to <i>Admin</i> state after you invoke the <code>resume</code> command, there is at least one unresolved problem that prevents the instance from going to <i>Replicating</i> state. See “Examine the Mirror Replication Agent logs” on page 160 for more information.

Examine the Mirror Replication Agent logs

The following is sample output from an Oracle instance's log file that can be located in the `$$SYBASE/MA-15_0/<inst_name>/log` directory:

```
W.      2005/04/26 11:33:23.075 OracleLogScanne
com.sybase.ds.oracle.log.OracleLogScanner  scanForward 23      The change
vector list for log record <00001610.000002d2.0170> is empty.

W.      2005/04/26 11:33:43.313 OracleLogScanne
com.sybase.ds.oracle.log.OracleLogScanner  scanForward 23      The change
vector list for log record <00001610.00000483.011c> is empty.

W.      2005/04/26 11:33:47.879 OracleLogScanne
com.sybase.ds.oracle.log.OracleLogScanner  scanForward 23      The change
vector list for log record <00001610.000004f7.012c> is empty.

T.      2005/04/26 11:35:28.867 OracleLogScanne
com.sybase.ds.oracle.log.OracleLogScanner  scanForward 23      Moving to log
<5649>.

E.      2005/04/26 11:35:30.359 ERROR
com.sybase.ds.oracle.log.record.RecordFactoryparseLogRecord 23
com.sybase.ds.oracle.record.UnknownRecordException: Unkown CVxE_4 inner op
type: <63>.

E.      2005/04/26 11:35:30.359 ERROR
com.sybase.ds.oracle.log.record.RecordFactoryparseLogRecord 23
java.lang.RuntimeException:
com.sybase.ds.oracle.record.UnknownRecordException: Unkown CVxE_4 inner op
type: <63>.

E.      2005/04/26 11:35:30.359 ERROR
com.sybase.ds.oracle.log.record.RecordFactoryparseLogRecord 23
com.sybase.ds.oracle.log.record.RecordFactory.createChangeVector (RecordFactor
y.java:430)
```

where:

- The first column displays a single character indicating the type of message:
 - I = information
 - W = warning
 - E = error
 - T = trace
 - S = severe

- The second column is a time stamp indicating when the message was written.
- The third column is a description.
- The fourth column identifies the Java class that produced the error.

Note The following two columns appear only when configuration property `log_trace_verbose` is set to true.

- The fifth column includes the method.
- The sixth column includes the line number.
- The final column is a text description of the message.

Note In some cases, the information in a specific column will not be consistent with these descriptions. In these cases, other information is generated that Technical Support uses to determine from where the message was generated.

Use the `ra_statistics` command to troubleshoot

The `ra_statistics` command returns activity-related statistics that you can use to evaluate Mirror Replication Agent operations and performance. By comparing the statistics returned when you first run the command to the statistics returned after you have successfully replicated something you know will work, you can analyze the differences in the statistics and troubleshoot where the problem lies. The statistics help you determine if the instance is:

- Scanning the transaction log
- Processing replicated transactions
- Sending LTL to the Replication Server

❖ To check Mirror Replication Agent operations

- 1 Log in to the Mirror Replication Agent instance with the administrator login.
- 2 Verify that you are in *Replicating* state. If you are not, change the state to *Admin*. For more information, see “Check the Mirror Replication Agent status” on page 158.

- 3 Use the following command to return statistics for all of the Mirror Replication Agent components and the Java VM:

```
ra_statistics
```

- 4 Save the statistics returned to use as a baseline for comparison.
- 5 Perform activity against the object that is not being replicated. For example, update a table that is not being replicated.
- 6 Repeat step 2.

Note Be sure to allow enough time for the Mirror Replication Agent to process the transaction.

- 7 Compare the newly-returned statistics activity with the baseline. Check for differences and see the following table.

If...	Then...
The value returned for <code>Total Maintenance User operations filtered</code> increases	You are executing the transaction as the Replication Server maintenance user for this Replication Server connection. By default, these transactions are not sent to Replication Server. You must either connect to the primary database as a different user, or you can set the configuration value of <code>filter_maint_userid</code> to <code>false</code> . See “Setting up the connection configuration parameters” on page 76.

Check available memory

If you are running out of memory, you see the following error message:

```
java.lang.OutOfMemoryError
```

When you are running out of memory, either the Mirror Replication Agent drops out of *Replicating* state or the entire Mirror Replication Agent server stops executing.

To support adjusting the amount of memory available to the JRE, all of the executable scripts (or batch files) in the Mirror Replication Agent *bin* directory refer to an environment variable named `RA_JAVA_MAX_MEM`. All Mirror Replication Agent instance *RUN* scripts also reference the `RA_JAVA_MAX_MEM` environment variable.

To adjust the amount of memory available to the JRE, do one of the following:

- Set the value of a system variable named `RA_JAVA_MAX_MEM` in your environment and use the `ra` utility to start the Mirror Replication Agent instance, or
- Set the value of the `RA_JAVA_MAX_MEM` variable in the Mirror Replication Agent instance *RUN* script and use the *RUN* script to start the Mirror Replication Agent instance.

If you start a Mirror Replication Agent instance by invoking the `ra` utility, you can set the value of the `RA_JAVA_MAX_MEM` system variable in your environment to specify the amount of memory available to the JRE. Before it sets the `RA_JAVA_MAX_MEM` variable to a default value, the `ra` and `ra_admin` utilities check to see if it is already set.

If you start a Mirror Replication Agent instance by invoking the instance *RUN* script (or batch file), you can edit the instance *RUN* script to change the default value of `RA_JAVA_MAX_MEM` and specify the amount of memory available to the JRE.

Note When a Mirror Replication Agent instance is started with the instance *RUN* script, the value of the `RA_JAVA_MAX_MEM` variable specified in the *RUN* script overrides the value set elsewhere. Therefore, you can edit the *RUN* script to adjust the memory available to the JRE for each instance.

Debugging LTL

LTL (Log Transfer Language) is the syntax used to communicate or distribute replication data to Replication Server. It is the principle output from a Mirror Replication Agent. For more details about LTL syntax, see the Replication Server *Design Guide*.

❖ To debug LTL

- 1 Log in to the running Mirror Replication Agent instance using the administrator login.
- 2 Verify that the Mirror Replication Agent instance is in *Admin* state:

```
ra_status
```

- 3 Set the values of the following Mirror Replication Agent configuration parameters for the primary database:

```
ra_config LITTRACELTL, true
```

- 4 Change the Mirror Replication Agent state to *Replicating*:

```
resume
```

- 5 When new replication activity is generated, check the *LTITRACELTL.log* file in the log directory to debug your problem.

Uncompressing LTL
for debugging a
problem

By default, the LTL generated by the Mirror Replication Agent is compressed to reduce the amount of data sent to Replication Server, reducing network bandwidth. In cases where you require more verbose output to help debug a problem, change the following configuration parameters to produce more verbose LTL.

❖ **To produce more verbose LTL**

- 1 Log in to the running Mirror Replication Agent instance using the administrator login.
- 2 Verify that the Mirror Replication Agent instance is in *Admin* state:

```
ra_status
```

- 3 Set the values of the following Mirror Replication Agent configuration parameters for the primary database:

```
ra_config column_compression = false
```

```
ra_config compress_ltl_syntax = false
```

```
ra_config structured_tokens = false
```

- 4 When new replication activity is generated, check the *LTITRACELTL.log* file in the log directory to debug your problem.

Checking the Replication Server

This section describes how to use Replication Server commands to check for the most common replication problems. For more detailed information about diagnosing and solving Replication Server problems, see the Replication Server *Troubleshooting Guide*.

Check status and operation

Replication Server provides several admin commands that you can use to check on its status and operation.

❖ To check the status and operation of the Replication Server

- 1 Log in to the Replication Server with a user login that has “sa” permission.
- 2 Use the following command to check the current status of the Replication Server:

```
admin health
```

This command returns the current status of the Replication Server, as shown in the following example:

Mode	Quiesce	Status
-----	-----	-----
NORMAL	FALSE	HEALTHY

If the Replication Server status is `SUSPECT`, use the `admin who_is_down` command to check for Replication Server threads that may be down or attempting to connect to other servers.

- 3 Use the following command to check the current status of the Replication Server database connections, including the connection from the Mirror Replication Agent to the Replication Server:

```
admin show_connections
```

You can also use the `admin who, dsi` command to get more information about the Mirror Replication Agent connection in the Replication Server.

Note You can use the `admin show_connections` or `admin who, dsi` command output to verify that the primary data server and primary database names are correct for the Mirror Replication Agent connection in the primary Replication Server.

For more information about the `admin show_connections` and `admin who` commands, see the Mirror Replication Agent *Reference Manual*.

Mirror Replication Agent login in Replication Server

Executing the Replication Server `connect source lti` command accomplishes three things:

- Verifies that the Replication Server database connection used by the Mirror Replication Agent exists in the Replication Server
- Verifies that the login name specified in the Mirror Replication Agent `rs_username` parameter has permission to connect to the Replication Server as a data source
- Returns a version string that shows the highest numbered version of LTL that the Replication Server supports

❖ **To verify that the `rs_username` login has appropriate permissions**

- 1 Log in to the Replication Server with the Mirror Replication Agent user login name specified in the `rs_username` configuration parameter.

Refer to the “Installation and Setup Worksheet” in the Mirror Activator *Installation Guide* for this login name.

- 2 Execute the connect source lti command:

```
connect source lti pds.pdb version
```

where:

- `pds` is the value specified for the Mirror Replication Agent `rs_source_ds` configuration parameter.
- `pdb` is the value specified for the Mirror Replication Agent `rs_source_db` configuration parameter.
- `version` is the proposed LTL version number.

Refer to the “Installation and Setup Worksheet” in the Mirror Activator *Installation Guide* for the values of the `rs_source_ds` and `rs_source_db` parameters.

Enter 999 for the value of the LTL version number. Replication Server returns the highest numbered version of LTL that it supports.

- 3 Disconnect from the Replication Server as `rs_username`, and then log in to the Mirror Replication Agent instance with the administrator login and invoke the resume command.

For more information about the connect source lti command, see the Replication Server *Design Guide* and Mirror Replication Agent *Reference Manual*.

Verify stable queues

Check the Replication Server stable queues to determine which transactions are being processed or ignored, and to determine whether transactions are open (not committed).

❖ To display information about SQM and SQT threads

- 1 Log in to the Replication Server and execute the `admin who, sqm` command.
- 2 View the results to determine the number of duplicate messages being detected and ignored, and the number of blocks being written in the Replication Server stable queues.
- 3 Execute the Replication Server `admin who, sql` command.
- 4 View the results to find open transactions.

For more information about the `admin who` command, see the Mirror Replication Agent *Reference Manual*.

Materializing Databases in a Mirror Activator system

This appendix describes how to materialize the databases in a Mirror Activator system.

Topic	Page
Selecting a materialization option	169

The procedures in this appendix assumes that:

- You have already installed the Mirror Replication Agent software and Replication Server software, as described in the Mirror Activator *Installation Guide* and the Replication Server installation and configuration guides for your platform.
- You have an existing, operational database, and you have configured that database as the primary database in a Mirror Activator system, as described in Chapter 2, “Setting Up and Configuring Mirror Replication Agent.”
- You have an existing, operational database, and you have configured that database as the standby database in a Mirror Activator system, as described in Chapter 2, “Setting Up and Configuring Mirror Replication Agent.”

Selecting a materialization option

The term *materialization* refers to the process of copying the contents of one database (the source) to another (the target), so that both databases contain identical data. This is the prerequisite condition (or starting point) for any system that provides continuous data replication, including the Mirror Activator system.

Materialization always replaces existing data (if any) in the target database with the data in the source database. Therefore, any process that copies only the differences between the source data and the target data (for example, an “incremental replication”) is not materialization.

Some materialization techniques copy all of the source data to the target, but for only part of the source database (for example, subscription materialization in Replication Server). Such techniques are not well suited for databases in the Mirror Activator system.

The Mirror Activator system is intended to replicate a complete database, with a one-to-one relationship between each object in one primary database and each object in one standby database. Because the Mirror Activator system relies on mirror log devices, which are exact copies of the primary database log devices, a device-level database materialization technique may be well suited for a Mirror Activator system.

Snapshot materialization allows you to take advantage of your disk replication system’s facilities to simplify the materialization process, and to reduce the time required for a complete database materialization.

Choosing the materialization technique to use will depend on several factors:

- Using your disk replication solution will typically provide the fastest transfer mechanism, but it may require skills that the typical DBA is not familiar with.
- Hardware system administrators may be comfortable with disk replication configuration and file system organization but less familiar with timing and commands required for database execution and reloading.
- Existing copy mechanisms used by your organization may provide slower raw transfer rates but faster overall execution time, simply due to having existing familiarity with the technique.

Therefore, the choice of materialization technique is left to individual discretion.

The Mirror Activator system setup procedures in Chapter 2, “Setting Up and Configuring Mirror Replication Agent,” and the failover and failback procedures in Appendix B, “Failover and Failback with Mirror Activator,” are based on using the snapshot materialization technique.

Note Snapshot materialization requires the primary database to be quiesced. To minimize primary database downtime, refer to the appropriate task checklist in the following sections and plan your materialization procedures carefully. For more information, refer to the Mirror Replication Agent *Primary Database Guide*.

Failover and Failback with Mirror Activator

This appendix describes tasks that you must incorporate in failover and failback procedures for the Mirror Activator system.

Topic	Page
Limitations and assumptions	173
Failover procedure	174
Failback procedure	177

Limitations and assumptions

This appendix does not consider all of the many possible configurations, options, and scenarios that can affect failover and failback procedures. It also does not consider the impact and interaction of any other system that might share resources with, or have some interdependency with the Mirror Activator system.

This appendix describes only failover and failback tasks that are specific to the Mirror Activator system. General failover and failback tasks, such as re-routing network connections and switching client access from one database to another, are *not* covered in this document.

The procedures in this appendix assume that:

- All Mirror Activator system components are set up and properly configured, as described in Chapter 2, “Setting Up and Configuring Mirror Replication Agent.” Also, when functioning normally, the Mirror Activator system is capable of replicating transactions from the primary database to the standby database, with no replication failures.
- The disk replication system is set up and configured to mirror all data devices, and to mirror all log devices to both the local site and the mirror log device site.

- The Mirror Activator system is essentially self-contained:
 - It is capable of operating independently of other systems and databases outside of its control.
 - It shares no system resources (including servers, networks, devices, and disk replication system facilities) with other systems that reside at the primary and standby sites.
 - All Mirror Activator system components—the primary and standby databases and all of their devices, disk replication system and mirror log devices, Mirror Replication Agent, and Replication Server—are dedicated solely to the Mirror Activator system.

Additional assumptions may apply to specific procedures in this appendix.

Failover procedure

Failover refers to the process of switching normal system operations from a primary database to a standby database, particularly in the event of a failure that interrupts:

- Operations at the primary database, or
- Access to the primary database.

You can also use a failover procedure to mitigate the impact of scheduled downtime on database users and clients (for example, when maintenance operations require the primary database to be offline).

This section describes only the failover tasks that are specific to the Mirror Activator system. General system failover procedures are not covered in this document.

Note The failover procedure described in this section does *not* use the Replication Server warm standby switch active feature. For information about switching the active and standby databases in a warm standby application, see the Replication Server *Administration Guide*.

Table B-1 provides a checklist of the tasks that you must include in failover procedures for the Mirror Activator system.

The checklist in Table B-1 assumes that:

- The primary database has gone offline, triggering the failover procedure to begin.
- To provide recovery from a standby database failure, you will use the disk replication system to capture and mirror all changes on the standby database devices while the primary database is offline.

Sybase recommends that you perform these tasks in the order shown.

Table B-1: Mirror Activator system failover tasks

Task	Description
1	Verify that the Mirror Replication Agent has finished processing the last transaction record in the log, and then stop replication in the Mirror Replication Agent.
2	Verify that the Replication Server has distributed the last committed transaction in the log.
3	Check the Replication Server stable queue for open transactions. Note Before failback, you must purge any open transactions that remain in the Replication Server stable queue.
4	Failover the disk replication system to: <ul style="list-style-type: none"> • Treat the standby database data and log devices as “primary” devices. • Mirror all subsequent changes on the standby database data and log devices to another set of standby (or backup) devices.
5	Switch access for users and client applications from the primary database to the standby database.

Use the following procedure for Mirror Activator system failover tasks.

❖ **To perform failover in the Mirror Activator system**

- 1 Verify that the Mirror Replication Agent has finished processing all transactions in the log, and then stop replication in the Mirror Replication Agent:
 - Log in to the Mirror Replication Agent administration port and execute the following command:

```
quiesce
```

The quiesce command completes once the Replication Agent has reached the end of the Primary database transaction log, and all generated LTL commands are sent to Replication Server.

For more information, see “Stopping replication in the Mirror Replication Agent” on page 96 and “Determining current Mirror Replication Agent status” on page 89.

- 2 Check the Replication Server stable queue for open transactions.

Log in to the Replication Server with a user login that has “sa” permission, and execute the following command:

```
admin who, sqt
```

Check the `admin who, sqt` output for the SQT thread associated with the standby database connection. The following column values indicate that all committed transactions have been distributed successfully, and that open (uncommitted) transactions remain in the stable queue:

- Closed – 0
- Open – (any number other than zero)
- SQM Blocked – 1
- First Trans – STO

Note Before failback, you must purge any open transactions that remain in the Replication Server stable queue.

For more information about the `admin who` command, see the Replication Server *Reference Manual*.

- 3 Fail over the disk replication system.

Reconfigure the disk replication system to:

- Treat the standby database data and log devices as “primary” (source) devices
- Mirror all subsequent changes on the standby database data and log devices to another set of standby (backup) devices, preferably at an alternate site (neither the primary nor standby site)

Refer to the documentation provided by your disk replication system vendor for more information about the procedures in this step.

- 4 After you complete all of the previous tasks, you can switch access for users and client applications from the primary database to the standby database.

Failback procedure

Failback refers to the process of restoring normal user and client access to a primary database, after a failover switched access from the primary database to a standby database.

This section describes only the failback tasks that are specific to the Mirror Activator system. General system failback procedures are not covered in this document.

Table B-2 provides a checklist of the tasks that you must include in failback procedures for the Mirror Activator system.

The checklist in Table B-2 assumes that:

- You have purged the Replication Server stable queue to remove any open transactions remaining after failover.
- The primary data server is up and functioning correctly, and you are ready to return it to normal operation.

Note If you do not purge the Replication Server stable queue to remove any open transaction that remained in the queue after failover:

- Replication will not start, because Replication Server will not send any new transactions to the standby database until it receives operations to complete the open transactions.
 - Eventually, the stable queue will run out of space, because Replication Server will not send any transactions after you resume replication upon failback.
-

Sybase recommends that you perform these tasks in the order shown.

Table B-2: Mirror Activator system failback tasks

Task	Description
1	Quiesce the standby database to suspend update activity.
2	Fail back the disk replication system to: <ul style="list-style-type: none"> • Re-materialize the primary database data and log devices from the standby database devices. • Materialize the mirror log devices at the standby site from the materialized primary log devices. • Re-establish synchronous replication from the primary log devices to the mirror log devices at the standby site.
3	Bring the primary database online.
4	Initialize the primary database using the <code>pdb_init move_truncpt</code> command to set the truncation point to the end of the log.
5	Quiesce the primary database.
6	Initialize the Mirror Replication Agent using the <code>ra_init force</code> command, and set the paths to the mirror log devices.
7	Release the quiesce on the primary database, <i>after</i> the Mirror Replication Agent initialization is complete.
8	Switch access for users and client applications from the standby database to the primary database.
9	Release the quiesce on the standby database, <i>after</i> client access is switched to the primary database.
10	Start replication in the Mirror Replication Agent with the <code>resume</code> command.

Use the following procedure for Mirror Activator system failback tasks.

❖ **To fail back the Mirror Activator system**

- 1 Quiesce the standby database to suspend update activity.
- 2 Fail back the disk replication system to:
 - Materialize the primary database data and log devices from the standby database devices.
 - Materialize the mirror log devices at the standby site from the materialized primary log devices.
 - Re-establish synchronous replication from the primary log devices to the mirror log devices at the standby site.

Refer to the documentation provided by your disk replication system vendor for more information about the procedures in this step.

For more information about re-materializing a primary database, see Appendix A, “Materializing Databases in a Mirror Activator system.”

- 3 Bring the primary database online.
- 4 Initialize the primary database using the Mirror Replication Agent `pdb_init move_trunct` command. This command sets the truncation point to the end of the log.

For more information about initializing the primary database, see “Setting up the Mirror Activator system” on page 17.

- 5 Quiesce the primary database.
- 6 Initialize the Mirror Replication Agent using the `ra_init force` command to update the system data repository in the RASD, and then use `ra_devicepath` to set the paths to the mirror log devices (if necessary).

For more information, see “Updating the RASD” on page 109.

- 7 Release quiesce on the primary database, *after* the Mirror Replication Agent initialization is complete.
- 8 Switch access for users and client applications from the standby database to the primary database.
- 9 Release quiesce on the standby database, after client access is switched to the primary database.
- 10 Start replication in the Mirror Replication Agent.

Log in to the Mirror Replication Agent administration port and execute the following command:

```
resume
```

After you invoke `resume`, use the `ra_status` command to verify that the Mirror Replication Agent is in *Replicating* state.

For more information, see “Starting replication in the Mirror Replication Agent” on page 95.

Glossary

This glossary describes Mirror Activator and Mirror Replication Agent terms used in this book.

Adaptive Server

The brand name for Sybase relational database management system (RDBMS) software products.

- *Adaptive Server Enterprise* manages multiple, large relational databases for high-volume online transaction processing (OLTP) systems and client applications.
- *Adaptive Server IQ* manages multiple, large relational databases with special indexing algorithms to support high-speed, high-volume business intelligence, decision support, and reporting client applications.
- *Adaptive Server Anywhere* manages relational databases with a small RDBMS footprint, which is ideal for embedded applications and mobile device applications.

See also **database** and **RDBMS**.

atomic materialization

A materialization method that copies subscription data from a primary database to a standby database in a single, atomic operation. No changes to primary data are allowed until the subscription data is captured at the primary database. See also **bulk materialization** and **nonatomic materialization**.

BCP utility

A bulk copy transfer utility that provides the ability to load multiple rows of data into a table in a target database. See also **bulk copy**.

bulk copy

An Open Client interface for the high-speed transfer of data between a database table and program variables. It provides an alternative to using SQL insert and select commands to transfer data. See also **BCP utility** and **materialization**.

bulk materialization	A materialization method whereby subscription data in a standby database is initialized outside of the replication system. You can use bulk materialization for subscriptions to table replication definitions or function replication definitions. See also atomic materialization , materialization , and nonatomic materialization .
client	In client/server systems, the part of the system that sends requests to servers and processes the results of those requests. See also client application .
client application	Software that is responsible for the user interface, including menus, data entry screens, and report formats. See also client .
commit	An instruction to the DBMS to make permanent the changes requested in a transaction. Contrast with rollback . See also DBMS and transaction .
data client	A client application that provides access to data by connecting to a data server. See also client , client application , and data server .
data distribution	A method of locating (or placing) discrete parts of a single set of data in multiple systems or at multiple sites. Data distribution is distinct from data replication, although a data replication system can be used to implement or support data distribution. Contrast with data replication .
data replication	The process of copying data to remote locations, and then keeping the replicated data synchronized with the primary data. Data replication is distinct from data distribution. Replicated data is stored copies of data at one or more remote sites throughout a system, and it is not necessarily distributed data. Contrast with data distribution . See also disk replication and transaction replication .
data server	A server that provides the functionality necessary to maintain the physical representation of a table in a database. Data servers are usually database servers, but they can be any data repository with the interface and functionality a data client requires. See also client , client application , and data client .
database	A collection of data with a specific structure (or schema) for accepting, storing, and providing data for users. See also data server and relational database .
database connection	A connection that allows Replication Server to manage the database and distribute transactions to the database. Each database in a replication system can have only one database connection defined in Replication Server. See also Replication Server and route .
datatype	A keyword that identifies the characteristics of stored information on a computer. Some common datatypes are: char, int, smallint, date, time, numeric, and float. Different data servers support different datatypes.

DBMS	An abbreviation for <i>database management system</i> , a computer-based system for defining, creating, manipulating, controlling, managing, and using databases. The DBMS can include the user interface for using the database, or it can be a stand-alone data server system. Compare with RDBMS . See also database .
disaster recovery	A method or process used to restore the critical business functions interrupted by a catastrophic event. A disaster recovery (or business continuity) plan defines the resources and procedures required for an organization to recover from a disaster, based on specified recovery objectives.
disk replication	A data replication method that copies blocks or pages from a primary disk device to a standby device. Sometimes referred to as <i>disk mirroring</i> . See also data replication and transaction replication .
failback	A procedure that restores the normal user and client access to a primary database, after a failover procedure switched access from the primary database to a standby database. Contrast with failover .
failover	A procedure that switches user and client access from a primary database to a standby database, particularly in the event of a failure that interrupts operations at the primary database, or access to the primary database. Failover is an important fault-tolerance feature for systems that require high availability. Contrast with failback .
ERSSD	An abbreviation for embedded <i>Replication Server System Database</i> , which manages replication system information for a Replication Server.
function	A Replication Server object that represents a data server operation, such as insert, delete, or begin transaction. Replication Server distributes operations to standby databases as functions. See also function string .
function string	A string that Replication Server uses to map a function and its parameters to a data server API. Function strings allow Replication Server to support replication between (homogeneous) non-Sybase data servers, and heterogeneous replication, in which the primary and replicate databases are different types, with different SQL extensions and different command features. See also function .
gateway	Connectivity software that allows two or more computer systems with different network architectures to communicate.
inbound queue	A stable queue managed by Replication Server to spool messages received from a Mirror Replication Agent. See also outbound queue and stable queue .

interfaces file	A file containing information that Sybase Open Client and Open Server applications need to establish connections to other Open Client and Open Server applications. See also Open Client and Open Server .
isql	An interactive SQL client application that can connect and communicate with any Sybase Open Server application, including Adaptive Server, Mirror Replication Agent, and Replication Server. See also Open Client and Open Server .
Java	An object-oriented, platform-independent, “write once, run anywhere” programming language developed by Sun Microsystems. The Mirror Replication Agent is a Java application.
Java VM	The Java Virtual Machine (JVM), which is the part of the Java Runtime Environment (JRE) that interprets Java byte codes. See also Java and JRE .
JDBC	An abbreviation for <i>Java Database Connectivity</i> , the standard communication protocol for connectivity between Java clients and data servers. See also client , data server , and Java .
jConnect	The Sybase JDBC driver that Mirror Replication Agent uses to connect to Replication Server and the RSSD.
JRE	An abbreviation for <i>Java Runtime Environment</i> , which consists of the Java Virtual Machine (Java VM or JVM), the Java Core Classes, and supporting files. To run a Java application, such as the Mirror Replication Agent, a JRE must be installed on the machine. See also Java and Java VM .
LAN	An abbreviation for “local area network,” a computer network located on the user’s premises and covering a limited geographical area (usually a single site). Communication within a local area network is not subject to external regulations; however, communication across the LAN boundary can be subject to some form of regulation. Contrast with WAN .
latency	<p>In transaction replication, the time it takes to replicate a transaction from a primary database to a standby database. Specifically, latency is the time elapsed between committing an original transaction in the primary database and committing the replicated transaction in the standby database.</p> <p>In disk replication, latency is the time elapsed between a disk write operation that changes a block or page on a primary device and the disk write operation that changes the replicated block or page on a mirror (or standby) device.</p> <p>See also disk replication and transaction replication.</p>

LOB	An abbreviation for <i>large object</i> , a type of data element (or datatype) associated with a column that contains extremely large quantities of data.
Log Reader	An internal component of the Mirror Replication Agent that interacts with the primary database and mirror log devices to capture transactions for replication. See also Log Transfer Interface .
Log Transfer Interface	An internal component of the Mirror Replication Agent that interacts with Replication Server to forward transactions for distribution to a standby database. See also Log Reader .
Log Transfer Language	The proprietary protocol used between Mirror Replication Agent and Replication Server to replicate data from the primary database to Replication Server. See also Log Reader and Log Transfer Interface .
Maintenance User	A special user login name in the standby database that Replication Server uses to apply replicated transactions to the database. See also Replication Server and standby database .
materialization	The process of copying the data from a primary database to a standby database, initializing the standby database so that the Mirror Activator system can begin replicating transactions. See also atomic materialization , bulk materialization , and non-atomic materialization .
Mirror Replication Agent	An application that reads a primary database transaction log to acquire information about data-changing transactions in the primary database, processes the log information, and then sends it to a Replication Server for distribution to a standby database. See also primary database , Replication Server , and standby database .
nonatomic materialization	A materialization method that copies subscription data without a lock on the primary database. Changes to primary data are allowed during data transfer, which may cause temporary inconsistencies between the primary and standby databases. Contrast with atomic materialization . See also bulk materialization .
ODBC	An abbreviation for <i>Open Database Connectivity</i> , an industry standard communication protocol for clients connecting to data servers. See also client , data server , and JDBC .
Open Client	A Sybase product that provides customer applications, third-party products, and other Sybase products with the interfaces needed to communicate with Open Server applications. See also Open Server .
Open Client application	An application that uses Sybase Open Client libraries to implement Open Client communication protocols. See also Open Client and Open Server .

Open Server	A Sybase product that provides the tools and interfaces required to create a custom server. See also Open Client .
Open Server application	A server application that uses Sybase Open Server libraries to implement Open Server communication protocols. See also Open Client and Open Server .
outbound queue	A stable queue managed by Replication Server to spool messages to a standby database. See also inbound queue , stable queue , and standby database .
primary data	The version of a set of data that is the source used for replication. Primary data is stored and managed by the primary database. See also primary database .
primary database	The database that contains the data to be replicated to another database (the standby database) through a replication system. The primary database is the source of replicated transactions and data in a replication system. Sometimes called the <i>active database</i> . Contrast with standby database . See also primary data and replicated transaction .
primary key	The column or columns whose data uniquely identify each row in a table.
primary site	The location or facility at which primary data servers and primary databases are deployed to support normal business operations. Sometimes called the <i>active site</i> or <i>main site</i> . See also primary database and standby site .
primary table	A table used as a source for replication. Primary tables are defined in the primary database schema. See also primary data and primary database .
primary transaction	A transaction that is committed in the primary database and recorded in the primary database transaction log. See also primary database and transaction log .
quiesce	To cause a system to go into a state in which further data changes are not allowed. See also quiescent .
quiescent	<p>In a replication system, a state in which all data-changing operations have been propagated to their destinations. Some Mirror Replication Agent and Replication Server commands require that you quiesce the replication system.</p> <p>In a database, a state in which all data-changing operations are suspended so that transactions cannot change any data, and the data and log devices are stable.</p> <p>This term is interchangeable with <i>quiesced</i> and <i>in quiesce</i>. See also quiesce.</p>

RASD	An abbreviation for <i>Replication Agent System Database</i> , information in which the primary database uses to recognize database structure or schema objects in the transaction log.
RCL	An abbreviation for <i>Replication Command Language</i> , the command language used to manage Replication Server. See also Replication Server .
RDBMS	An abbreviation for <i>relational database management system</i> , which is an application that manages and controls relational databases. Compare with DBMS . See also relational database .
relational database	A collection of data in which data is viewed as being stored in tables, which consist of columns (data items) and rows (units of information). Relational databases can be accessed by SQL requests. Compare with database . See also SQL .
replicated data	A set of data that is replicated from a primary database to a standby database by a replication system. See also primary database , replication system , and standby database .
replicated transaction	A primary transaction that is replicated from a primary database to a standby database by a transaction replication system. See also primary database , primary transaction , standby database , and transaction replication .
replication definition	A description of a table or stored procedure in a primary database, for which subscriptions can be created. The replication definition, maintained by Replication Server, includes information about the columns to be replicated and the location of the primary table or stored procedure. See also Replication Server and subscription .
Replication Server	The Sybase software product that provides the infrastructure for a robust transaction replication system. See also Mirror Replication Agent .
RSSD	An abbreviation for <i>Replication Server System Database</i> , which manages replication system information for a Replication Server. See also Replication Server .
replication system	A data processing system that replicates data from one location to another. Data can be replicated between separate systems at a single site, or from one or more local systems to one or more remote systems. See also data replication , disk replication , and transaction replication .
rollback	An instruction to a database to reverse the data changes requested in a unit of work (a transaction). Contrast with commit . See also transaction .

SQL	An abbreviation for <i>Structured Query Language</i> , a non-procedural programming language used to process data in a relational database. ANSI SQL is an industry standard. See also transaction .
stable queue	A disk device-based, store-and-forward queue managed by Replication Server. Messages written into the stable queue remain there until they can be delivered to the appropriate process or standby database. Replication Server provides a stable queue for both incoming messages (the inbound queue) and outgoing messages (the outbound queue). See also database connection and Replication Server .
standby data	The data managed by a standby database, which is the destination (or target) of a replication system. Contrast with primary data . See also standby database and replication system .
standby database	A database that contains data replicated from another database (the primary database) through a replication system. The standby database is the database that receives replicated transactions and/or data in a replication system. Sometimes called the <i>replicate database</i> . Contrast with primary database . See also replicated transaction , replication system , and standby data .
standby site	The location or facility at which standby data servers and standby databases are deployed to support disaster recovery, and normal business operations during scheduled downtime at the primary site. Sometimes called the <i>alternate site</i> or <i>replicate site</i> . Contrast with primary site . See also standby database .
subscription	A request for Replication Server to maintain a replicated copy of a table, or a set of rows from a table, in a standby database at a specified location. See also replication definition , Replication Server , and standby database .
table	In a relational database, a two-dimensional array of data, or a named data object that contains a specific number of unordered rows composed of a group of columns that are specific to the table. See also database and relational database .
transaction	A unit of work in a database that can include zero, one, or many operations (including insert, update, and delete operations), and that is either applied or rejected as a whole. Each SQL statement that modifies data can be treated as a separate transaction, if the database is so configured. See also replicated transaction and SQL .

transaction log	Generally, the log of transactions that affect the data managed by a data server. Mirror Replication Agent reads the transaction log to identify and acquire the transactions to be replicated from the primary database. See also Mirror Replication Agent , primary database , and transaction .
transaction replication	A data replication method that copies data-changing operations from a primary database to a standby database. See also data replication , primary database , and standby database .
transactional consistency	A condition in which all transactions in the primary database are applied in the standby database, and in the same order that they were applied in the primary database. See also primary database , standby database , and transaction .
WAN	An abbreviation for “wide area network,” a system of local-area networks (LANs) connected together with data communication lines. Contrast with LAN .

Index

A

Admin state 90–91
administration port 44, 68–71
 connecting to 68–70
administrator login 70–71

B

backing up
 RASD 114–115
base directory, Mirror Replication Agent 26, 43

C

changing
 Mirror Replication Agent state 92–93
character sets 64
charset 64
client ports
 interfaces file 68–69
 Mirror Replication Agent 44, 68–71
 primary database 77–78
 Replication Server 78, 80
 RSSD 73–75
commands
 pdb_setrepcol 87, 129, 130
 pdb_setrepDDL 125
 pdb_setrepddl 88
 pdb_setrepproc 85–86, 103, 133–136, 138, 139
 pdb_setrepseq 144
 pdb_setreptable 83, 84, 103, 121, 123, 124, 126,
 127
 pdb_xlog 100, 102, 104
 quiesce 97–98
 ra_config 100, 144, 151
 ra_set_login 70
 ra_statistics 93, 161

ra_status 90, 156–159
 resume 95–96
 shutdown 93–95
 suspend 98–99
 test_connection 80–82
communications
 See also connections
 administration port 68–70
 JDBC driver 13–14, 15
 RSSD parameters 73–75
 setting up connectivity 71–80
 testing connections 80–82
configuration files 44–45, 46, 56–59
configuration parameters
 copied from existing instance 58
 pdb_auto_run_scripts 101
 pdb_dflt_object_repl 120, 122, 132, 134, 140
 pdb_xlog_prefix 30, 31, 100, 102
 tuning recommendations 151, 153
configuring
 disk replication system 38
 Mirror Activator system 17
 mirror log devices 38–39
 Mirror Replication Agent 39, 76–80
 standby databases 40
connect source permission 39, 73
connections
 configuring 76–80
 rssd_port_number parameter 73–75
creating
 transaction log 30, 100–102
creating a Mirror Replication Agent instance 46–59

D

data definition language
 See DDL commands
database connections
 Mirror Replication Agent 77–78

Index

- database devices
 - log device repository 112–114
 - mirror device configuration 38–39
 - database objects
 - DDL 88, 124
 - LOB columns 86
 - transaction log object names 30
 - transaction log prefix 30
 - databases
 - See* Adaptive Server; primary databases; standby databases
 - DDL
 - disabling replication 125
 - enabling replication for 88, 124
 - DDL commands
 - effect on RASD 108–109
 - replicated 108–109
 - deleting
 - transaction log 102–104
 - deleting a Mirror Replication Agent instance 59
 - devices
 - See* database devices; log devices
 - disabling column replication 130–131
 - disabling DDL replication 125
 - disabling sequence replication 143–144
 - disabling stored procedure replication 132, 137–138
 - disabling table replication 126, 127–128
 - disk replication system
 - configuration requirements 38
 - failover and failback 173–179
 - materialization procedures 9–10, 34–35
 - disk replication systems
 - configuration requirements 38
- ## E
- enabling column replication 86–87, 129–130
 - enabling DDL replication 88, 124
 - enabling stored procedure replication 136–137, 142–143
 - enabling table replication 126–127
 - environment, SYBASE variable 40
 - errors
 - general troubleshooting 155
 - replication failure 155
 - starting up Mirror Replication agent 43
- ## F
- failover and failback
 - procedures 174–179
 - re-materializing primary database 178–179
 - files
 - configuration 44–45, 46, 56–59
 - interfaces 68–69
 - manifest file (external dump) 33
 - Mirror Replication Agent base directory 26, 43
- ## G
- granting permissions
 - connect source** in Replication Server 73
- ## H
- host machines
 - Mirror Replication Agent 43, 68–70
 - RSSD 73–75
- ## I
- immediate shutdown 94
 - initializing
 - Mirror Replication Agent 35, 108
 - primary database 32
 - initializing Mirror Replication Agent 109
 - installing
 - Mirror Activator components 18–19
 - Mirror Replication Agent 26
 - instance, Mirror Replication Agent 26
 - changing state 92–93
 - configuration requirements 39
 - creating 46–59
 - deleting 59
 - initializing 108, 109
 - name 26, 42, 44
 - setting up connectivity 30, 71–80
 - shutting down 93–95
 - starting 61–67
 - status 89–92
 - interfaces file 68–69

J

- Java Runtime Environment (JRE) 11
- JDBC driver 13–14, 15

L

- LOB columns
 - disabling replication for 130–131
 - enabling replication for 86–87, 129–130
- log devices
 - mirror configuration requirements 38–39
 - updating repository 112–114
- Log Reader component 12
- Log Transfer Manager component 12

M

- ma** utility 42–43
 - start-up state 42
 - syntax 42, 43
- ma_admin** utility 43
 - syntax 44, 46, 47
- manifest file, external dump 33
- marking
 - tables 119–123
- marking a primary table 82–84, 123
- marking a sequence 138–141
- marking a stored procedure 86, 131–134
- materialization
 - failback procedure 178–179
 - primary database 10, 178–179
 - procedures 169
 - standby database 9–10, 34–35
- Mirror Activator
 - components 7–16
 - configuration requirements 38–40
 - configuring 19
 - installing components 18–19
 - introduction 4–16
 - setting up system 17
 - system 5, 6–16
- mirror log devices
 - See* database devices; log devices
- Mirror Replication Agent

- Admin* state 90–91
- administration port 44, 68–71
- administrator login 70–71
- base directory 26, 43
- communications 13–14, 14–15, 30, 68–70, 71–80
- configuration file 44–45, 56–59
- configuration requirements 39
- configuring connections 76–80
- creating an instance 46–59
- creating transaction log 30
- deleting an instance 59
- host machine 43, 68–70
- initializing an instance 35, 108, 109
- installing 26
- instance name 42, 44
- introduction 11–16
- Log Reader component 12
- Log Transfer Manager component 12
- performance statistics 93
- performance tuning 144, 151, 153
- primary database user login 72
- quiescing 97–98
- RASD 107, 117
- Replicating* state 90–92
- Replication Server user login 73
- RSSD user login 73–75
- RUN** script 66–67
 - setting up 30
- shutting down an instance 93–95
- starting an instance 61–67
- starting replication 95–96
- start-up state 42
- statistics, performance 93
- stopping replication 96
- suspending 98
- system data repository 107, 114
- testing connections 80–82
- transaction log prefix 31
- troubleshooting 155, 167
- utilities 40
- version 43
- mro** utility 65

N

names

- host machine 73–75
- Mirror Replication Agent instance 26, 42, 44
- primary database user logins 72
- Replication Server user logins 73
- RSSD database name 73–75
- RSSD user logins 73–75
- transaction log objects 30

O

- Open Client interfaces file 68–69
- Oracle database server
 - connection from Mirror Replication Agent 77–78
 - user logins 72

P

- passwords
 - RSSD user login 73–75
- pdb_auto_run_scripts** configuration parameter 101
- pdb_dflt_object_repl** configuration parameter 120, 122, 132, 134, 140
- pdb_setrepcol** command 87, 129, 130
- pdb_setrepDDL** command 125
- pdb_setrepddl** command 88
- pdb_setrepproc** command 85–86, 103, 133–136, 138, 139
- pdb_setrepseq** command 144
- pdb_setreptable** command 83, 84, 103, 121, 123, 124, 126, 127
- pdb_xlog** command 100, 102, 104
- pdb_xlog_prefix** configuration parameter 30, 31, 100, 102
- performance statistics 93
- performance tuning 144, 151, 153
- permissions
 - connect source** in Replication Server 39, 73
- port numbers
 - RSSD 73–75
- prefix, transaction log 30, 31, 100, 102
- primary databases
 - connection from Mirror Replication Agent 77–78

- initializing 32
- quiescing 33, 36
- re-materializing for failback 10, 178–179
- testing connections 80–82
- transaction log 99, 104
- user logins 72
- primary tables
 - disabling replication 103, 126, 127–128
 - enabling replication 126–127
 - marking 82–84, 119–123
 - subscriptions to 14, 15
 - unmarking 103, 123–124
- procedures
 - failover and failback 174–179
 - Mirror Activator configuration 19

Q

queues

- Replication Server 167
- quiesce** command 97–98
- quiescing
 - Mirror Replication Agent 97–98
 - primary databases 33, 36

R

- ra_config** command 100, 144, 151
- ra_set_login** command 70
- ra_statistics** command 93, 161
- ra_status** command 90, 156–159
- RASD 107, 117
 - backing up 114–115
 - DDL commands 108–109
 - forcing update 110, 112
 - initializing 108
 - log device repository 112–114
 - operations 107–109
 - restoring 115–116
 - truncating 116, 117
 - updating 108, 112, 114
- releasing primary database hold 36
- re-materializing primary database for failback 10, 178–179

- replicating DDL commands 108–109
 - Replicating* state 90–92
 - Replication Agent
 - configuration file 46
 - creating transaction log 100–102
 - removing transaction log 102–104
 - transaction log 99–107
 - transaction log prefix 100, 102
 - Replication Agent System Database
 - See* RASD
 - replication definitions 14, 15
 - Replication Server
 - connect source lti** command 165–166
 - connect source** permission 39, 73
 - connection from Mirror Replication Agent 78, 80
 - replication definitions 14, 15
 - SQM and SQT threads 167
 - stable queues 167
 - subscriptions 14, 15
 - testing connections 80–82
 - troubleshooting 164, 167
 - user logins 73
 - repository
 - system data 107, 114
 - requirements
 - Mirror Activator configuration 38–40
 - restoring
 - RASD 115–116
 - resume** command 95–96
 - RSSD 14, 15
 - connection from Mirror Replication Agent 73–75
 - database name 73–75
 - host machine name 73–75
 - Mirror Replication Agent user login 73–75
 - port number 73–75
 - user logins 73–75
 - RUN** script
 - Mirror Replication Agent 66–67
- S**
- scripts
 - transaction log creation 102
 - sequence
 - disabling replication 143–144
 - marking 141
 - unmarking 141
 - sequences
 - marking 138
 - setting up
 - Mirror Activator system 17
 - Mirror Replication Agent connections 76–80
 - Mirror Replication Agent connectivity 30, 71–80
 - shutdown** command 93–95
 - immediate** option 94
 - shutting down Mirror Replication Agent 93–95
 - socket port number
 - RSSD 73–75
 - SQM and SQT threads 167
 - stable queues 167
 - See also* queues
 - standby databases
 - configuration requirements 40
 - configuring 22
 - materializing 9–10, 34–35, 169
 - starting
 - Mirror Replication Agent 61–67
 - replication 95–96
 - states
 - Mirror Replication Agent start-up 42
 - states of Mirror Replication Agent 89–92
 - Admin* state 90–91
 - changing 92–93
 - Replicating* state 90–92
 - statistics, performance 93
 - stopping
 - replication 96–99
 - stored procedures
 - disabling replication 132, 137–138
 - enabling replication 136–137, 142–143
 - marking 86, 131–134
 - unmarking 103, 135–136
 - subscriptions to primary tables 14, 15
 - suspend** command 98–99
 - suspending Mirror Replication Agent 98
 - SYBASE environment variable 40
 - syntax
 - ma** utility 43
 - ma_admin** utility 44, 46, 47
 - system data repository 107, 114
 - See also* RASD

Index

forcing update 110, 112
initializing 108–109
updating 108, 112

T

tasks

failover and failback 174–179
Mirror Activator configuration 19
test_connection command 80–82
transaction log prefix 30
transaction logs 99
 creating 30, 100–102
 creation script 102
 object names 30
 prefix 30, 100, 102
 prefix characters 31
 removing 102–104
 Replication Agent 99–107
 truncating 105–107
transaction replication 2–5
troubleshooting 155, 167
 Replication Server 167
 Replication Server connections 165–166
 start-up errors 43
truncating
 RASD 116, 117
tuning Mirror Replication Agent performance 144, 153

U

unmarking a primary table 103, 123–124
unmarking a sequence 141
unmarking a stored procedure 103, 135–136
updating
 log device repository 112–114
 RASD 108, 112
 system data repository 108, 112
user IDs
 Mirror Replication Agent administrator login 70–71
 primary database logins 72
 Replication Server 165–166
 Replication Server logins 73
 RSSD logins 73–75

utilities

isql 68–70
ma utility 42–43
ma_admin utility 43
Mirror Replication Agent 40

V

variable, SYBASE environment 40
version
 Mirror Replication Agent 43
versions
 troubleshooting 161